



MOT202TSA/MOT202TRM Modem User's Guide

0049-0119-000, Rev. D

The products and programs described in this User's Guide are licensed products of Raymar-Telenetics. This User's Guide contains proprietary information protected by copyright, and this User's Guide and all accompanying hardware and documentation are copyrighted.

Raymar Information Technology, Inc. does not warrant that the hardware will work properly in all environments and applications, and makes no warranty and representation, either implied or expressed, with respect to the quality, performance, merchantability, or fitness for a particular purpose.

Information in this User's Guide is subject to change without notice and does not represent a commitment on the part of Raymar Information Technology, Inc. Raymar Information Technology, Inc. assumes no responsibility for any inaccuracies that may be contained in this User's Guide.

Raymar Information Technology, Inc. makes no commitment to update or keep current the information in this User's Guide, and reserves the right to make changes to this User's Guide and/or product without notice.

No part of this manual may be reproduced or transmitted in any form or by any means, electronic or mechanical, including photocopying, recording, or information storage and retrieval systems, for any purpose other than the purchaser's personal use, without the express written permission of Raymar Information Technology, Inc.

© Copyright 2008 Raymar Information Technology, Inc.
7325 Roseville Road
Sacramento, California 95842
Tel: 800-695-1951
Direct: (916) 783-1951
Fax: (916) 783-1952

Contents

CHAPTER 1 INTRODUCTION.....	5
SUMMARY OF KEY FEATURES	5
MODELS	6
USING THIS MANUAL	6
CONTACT INFORMATION	7
CHAPTER 2 INSTALLING THE MODEM.....	9
SITE PREPARATION.....	9
UNPACKING YOUR HARDWARE.....	9
ADDITIONAL ITEMS YOU NEED	10
HARDWARE OVERVIEW	10
CONFIGURING THE MODEM	11
<i>Jumper S1 – Carrier Detect Control.....</i>	<i>14</i>
<i>Jumper S2 – Transmit Level.....</i>	<i>14</i>
<i>Jumper S3 – 2-wire/4-wire Mode.....</i>	<i>15</i>
<i>Jumper S4 – Call Turnaround Squelch.....</i>	<i>15</i>
<i>Jumper S5 – Transmit Carrier</i>	<i>16</i>
<i>Jumper S6 – Local Copy</i>	<i>16</i>
<i>Jumper S8 – Signal and Earth Ground.....</i>	<i>16</i>
<i>Jumper S9 – RTS-CTS Delay</i>	<i>17</i>
<i>Jumper S10 – Carrier Detect Delay.....</i>	<i>17</i>
<i>Jumper S11 – Turnaround Squelch Time.....</i>	<i>17</i>
<i>Jumper S12 – Soft Carrier Turn Off.....</i>	<i>18</i>
<i>Jumper S13 – Anti-Streaming</i>	<i>18</i>
<i>Jumpers S14 and S15 – Self Test or Test Pattern.....</i>	<i>19</i>
CONNECTING A DTE	19
CONNECTING TO A PRIVATE LINE COMMUNICATION CIRCUIT.....	19
Connecting to an AC Power Source.....	19
Powering-on the Modem	20
Powering-off the Modem	20

Contents

CHAPTER 3 LEDS AND CONTROLS	21
FRONT PANEL LEDS.....	21
FRONT PANEL TEST SWITCH.....	22
CHAPTER 4 TROUBLESHOOTING.....	25
LOCAL MODEM TEST.....	25
LINE AND MODEM TEST	26
CHAPTER 5 SPECIFICATIONS.....	27
GENERAL.....	27
DIMENSIONS AND WEIGHT	28
TEMPERATURE RANGE	28
POWER REQUIREMENTS	28
INTERFACE PIN ASSIGNMENTS.....	29
<i>DTE Connector - EIA RS-232-C</i>	29
<i>Telco Connector</i>	29
APPENDIX A COMPLIANCES.....	31
APPENDIX B LIMITED PRODUCT WARRANTY.....	33
APPENDIX C, RMA PROCEDURE.....	35

Chapter 1

Introduction

The Telenetics MOT202TSA standalone modem and MOT202TRM rack-mount modem are Frequency Shift Keyed (FSK) modems designed for asynchronous half-duplex communication on 2-wire private line circuits or full-duplex communication on 4-wire private-line circuits.

Summary of Key Features

The following list summarizes the modem's key features.

- Bell 202T compatible.
- Operates over voice-grade leased lines or private lines.
- 0 to 1200 bps operation for unconditioned line.
- 0 to 1800 bps operation for conditioned line (C2).
- Point-to-point or point-to-multipoint polling network.
- 4-wire full-duplex or 2-wire half-duplex leased-line configuration.
- Analog Loopback Test, Digital Loopback Test, Self Test, and Test Pattern Transmit.
- LED displays for power, RS-232 control, data status, and test mode.

Introduction

Models

The Telenetics modem is available in two models:

- ❖ The MOT202TSA is a desktop modem.
- ❖ The MOT202TRM is a rack-mount modem that installs into a standard 19-inch rack.

In this manual, the term “modem” will be used to refer to both models collectively. If information pertains to one model only, that model will be identified by its model number.

Using This Manual

This manual contains all the information you need to install, configure, use, and test your modem.

- ❖ Chapter 1 contains general information on what the 202T modem does, contents of this manual, and contact information for Telenetics.
- ❖ Chapter 2 describes how to install and configure the modem.
- ❖ Chapter 3 provides general operating procedures.
- ❖ Chapter 4 provides troubleshooting procedures.
- ❖ Chapter 5 lists the modem’s specifications.

Contact Information

For more information about Telenetics' MOT202TSA and MOT202TRM modems, or other Telenetics solutions, please contact us using any of the following methods.



Voice Calls

We welcome your calls at **800-695-1951** Monday through Friday, from 7:00 am to 5:00 pm Pacific Time.



Fax Number

You can also send your requests for information to our 24-hour fax number: **916-783-1952**.



E-mail

If you prefer, you can send information requests to our 24-hour e-mail address: **sales@raymarinc.com**.



Website

Our website contains valuable information about our products. We encourage you to visit us online at **www.raymarinc.com**.

Chapter 2

Installing the Modem

This chapter describes how to install the modem.

Site Preparation

The location where you install your modem should be:

- Within six feet of a 115 or 230 VAC grounded outlet not controlled by a wall switch
- No more than 50 feet from the data terminal equipment
- Away from extremes of temperature, humidity, and appreciable shock.

Note: Be sure that there is a 4-inch minimum space at the back of the modem for signal line and interface cable clearance.

Unpacking Your Hardware

Your package should include at least one MOT202TSA or MOT202TRM modem, one RJ-45 jack-to-4 wire leased line cable, and this Installation Guide. If your package contents are damaged or missing, please contact your place of purchase immediately.

Installing the Modem

Additional Items You Need

To use your modem, you need the following additional items:

- ❖ *All users:* an RS-232 cable to connect a data terminal. The cable must conform to the pin assignments shown on page 29.
- ❖ *Standalone modem users:* a two- or four-wire transmission line or leased line and power supply.
- ❖ *Rack-mount modem users:* a modem rack with an available slot for installing the modem.

Hardware Overview

Figures 2-1 and 2-2 show the front and back modem panels of Standalone.



Figure 2-1 Front Panel



Figure 2-2. Back Panel

On the front panel of the modem, there are:

- ❖ One Power LED and six status LEDs (see page 21)
- ❖ A rotary test switch (see page 22)

On the back panel of the MOT202TSA modem, there are:

- ❖ A power cord or power input connector
- ❖ A power switch for turning the modem on and off
- ❖ A fuse, 3/8 amp, 250 Volt, slow-blow
- ❖ A DB25 female connector for accommodating a DTE device
- ❖ An RJ-45 connector for connecting to a communications line

Configuring the Modem

The modem obtains some operating characteristics from jumper settings. The default jumper settings are for common 4-wire full-duplex applications. To reconfigure the modem for 2-wire half-duplex and special applications, you must change the default jumper settings.

To change jumper settings, push the two tabs on the back of the modem to open the modem cover and gain access to the jumper settings on the printed circuit board (see Figure 2-3). Then set the jumpers to the desired settings and replace the cover.

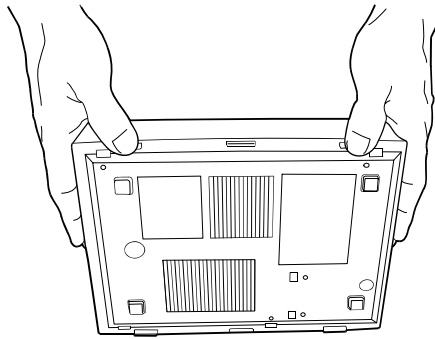

Figure 2-3. Gaining Access to the Modem Jumpers

Installing the Modem

Figure 2-4 on the next page shows the location of the modem jumpers. Table 2-1 on page 13 summarizes the jumper settings (default settings are **bold**).

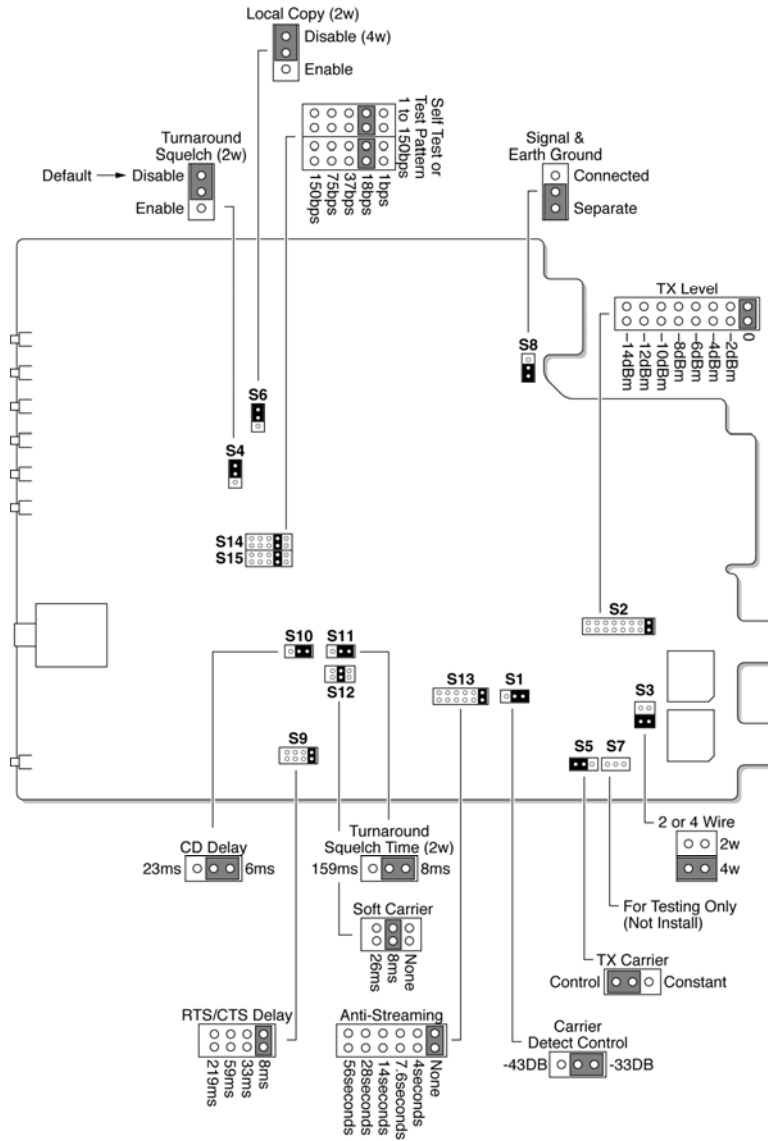

Figure 2-4. Modem Jumper Locations

Table 2-1. Jumper Settings

Jumper	Function	Settings	See Page...
S1	Carrier Detect control	-33 dBm -43 dBm	14
S2	Transmit level	0dBm -2 dBm -4 dBm -6 dBm -8 dBm -10 dBm -12 dBm -14 dBm	14
S3	2-wire/4-wire mode	2-wire 4-wire	15
S4	Call turnaround squelch	Enabled Disabled	15
S5	Transmit carrier	Control Constant	16
S6	Local copy	Enabled Disabled	16
S8	Signal and Earth ground	Connected Separate	16
S9	RTS-CTS delay	8 ms 33 ms 59 ms 219 ms	17
S10	Carrier Detect delay	6 ms 23 ms	17
S11	Turnaround squelch time (Enabled by jumper S4)	8 ms 159 ms	17
S12	Soft Carrier turn off	None 8 ms 26 ms	18
S13	Anti-streaming	None 4 seconds 7.6 seconds 14 seconds 28 seconds 56 seconds	18
S14 and S15	Self Test or test pattern (Tx and Rx pattern speed)	1 bps 18 bps 37 bps 75 bps 150 bps	19

Installing the Modem

Note: The jumper positions in the following sections reflect the position of the jumpers on the modem board when you face the board as indicated in Figure 2-4 on page 12.

Jumper S1 – Carrier Detect Control

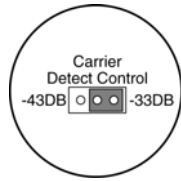

Settings: -33 dBm (*default*)
-43 dBm

Jumper **S1** configures the dynamic range of the modem receiver. The selections are either -33 dBm or -43 dBm. If the incoming signal is above -24 dBm, use the default -33 dBm setting. If the modem is operated on the network, use the -43 dBm setting.

Jumper S2 – Transmit Level

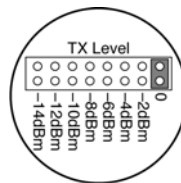

Settings: 0 dBm (*default*)
-2 dBm
-4 dBm
-6 dBm
-8 dBm
-10 dBm
-12 dBm
-14 dBm

Jumper **S2** adjusts the modem's transmit level. There are eight transmit level settings you can choose. By default, the modem uses a transmit level of 0 dBm.

Jumper S3 – 2-wire/4-wire Mode

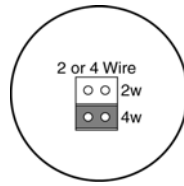

Settings: 2-wire
4-wire (*default*)

Jumper **S3** configures the modem for 2-wire or 4-wire operation.

- ❖ When configured for 4-wire full-duplex operation, jumper **S5** can be strapped to maintain constant carrier from the master modem to all slave modems at all times after the initial training. This enables the master modem to transmit data to the slave modems, with no RTS-to-CTS delay. This is the preferred operating mode when minimum turnaround is desired.
- ❖ When configured for 2-wire half-duplex operation, the modem encounters an RTS-to-CTS delay when transmitting to slave modems, increasing the turnaround time. Set jumper **S5** to controlled carrier for 2-wire half-duplex operation.

Jumper S4 – Call Turnaround Squelch

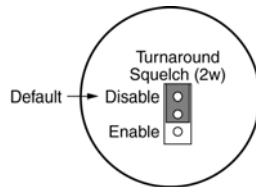

Settings: Enabled
Disabled (*default*)

Jumper **S4** configures the modem's Call Turnaround Squelch setting. For 2-wire, half-duplex communications, set this strap to the Enabled position. In this position, the receiver is inhibited for a period of time after the local transmitter is turned OFF. This guards against echoes caused by the transmission just completed. The time is determined by the turnaround squelch time option (jumper **S11**).

For 4-wire, full-duplex communications, keep the jumper set to the default position of Disabled.

Installing the Modem

Jumper S5 – Transmit Carrier

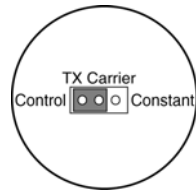

Settings: Control (*default*)
Constant

Jumper **S5** places the transmitter under terminal control (*default*) or turns on the transmitter continuously in a 2-wire half duplex system.

Jumper S6 – Local Copy

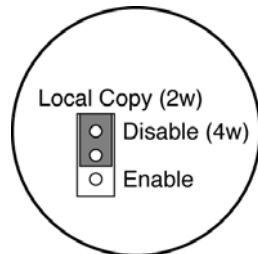

Settings: Enabled
Disabled (*default*)

Jumper **S6** must be left in the default position of Disabled when operating on a 4-wire network. It is also normally left in the default Disabled position when operating on a 2-wire network. Strapping this jumper as Disabled inhibits the local receiver from receiving the transmission of the local transmitter.

Jumper S8 – Signal and Earth Ground

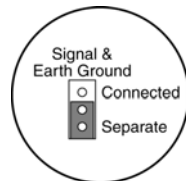

Settings: Connected
Separate (*default*)

Jumper **S8** allows Earth GND to be tied to the modem system GND.

Jumper S9 – RTS-CTS Delay

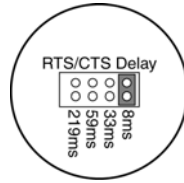

Settings: 8 ms (*default*)
33 ms
59 ms
219 ms

Jumper **S9** configures the modem's RTS-CTS delay. Four choices for selecting an RTS-CTS delay are available.

Jumper S10 – Carrier Detect Delay

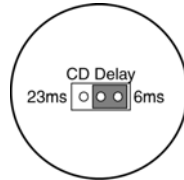

Settings: 6 ms (*default*)
23 ms

Jumper **S10** configures the modem's Carrier Detect turn on Delay timing. The delay chosen must be consistent with the Clear To Send delay selection of the transmitting modem and must be less than the CTS delay. The available delays are 6 ms (*default*) and 23 ms. The carrier detect drop out is less than 6 ms.

Jumper S11 – Turnaround Squelch Time

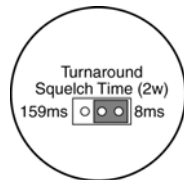

Settings: 8 ms (*default*)
159 ms

Jumper **S11** is used with the call turnaround squelch option (jumper **S4**). The available times are 8 ms (*default*) and 159 ms.

Installing the Modem

Jumper S12 – Soft Carrier Turn Off

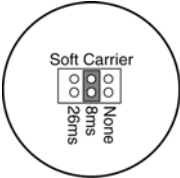

Settings: None
8 ms (*default*)
26 ms

Jumper **S12** configures the modem to either turn off the transmitter immediately upon release of Request To Send, or send a Soft Carrier Turn Off signal of 900 Hz for 8 or 26 ms at the end of each transmission.

Jumper S13 – Anti-Streaming

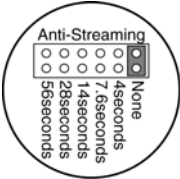

Settings: None (*default*)
4 seconds
7.6 seconds
14 seconds
28 seconds
56 seconds

Jumper **S13** lets you select an anti-streaming time or use no anti-streaming at all. Anti-streaming is typically used in multi-point applications to prevent a malfunctioning slave from occupying the line indefinitely.

When anti-streaming is active, the modem can only transmit data for up to 56 seconds. Thereafter, the modem’s transmitter is automatically turned off. The modem then looks for an ON-to-OFF transition of Request To Send (RTS) before proceeding with normal operation.

Jumpers S14 and S15 – Self Test or Test Pattern

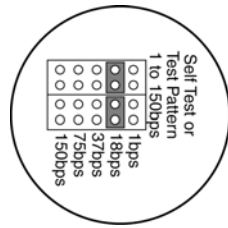

Settings: 1 bps
18 bps (*default*)
37 bps
75 bps
150 bps

Jumpers **S14** and **S15** configures the modem for Self Test or Test Pattern. When the modem is in local Self Test or Test Pattern mode, it generates a dot test pattern. The supported baud rates are 1 bps, 18 bps, 37 bps, 75 bps, or 150 bps.

Connecting a DTE

The modem back panel provides a standard, 25-pin port labeled **DTE**, which connects to an RS-232 device. The connectors for this port conform to the pin assignments shown under “DTE Connector – EIA RS-232-C” on page 29.

The DTE should have a cable no longer than 50 feet, with a Cinch or Cannon plug per DB-19604-432 plus a DB-51225-1 hood or equivalent.

Connecting to a Private Line Communication Circuit

The modem back panel provides an 8-pin RJ-45 connector labeled **TELCO**, which connects to a private line communication circuit. The connectors for this port conform to the pin assignments shown under “Telco Connector” on page 29.

Connecting to an AC Power Source

The modem back panel provides an AC line cord. If the chassis ground is connected through the third prong of the AC power plug, a separate chassis ground wire is required.

Installing the Modem

Powering-on the Modem

To supply power to the modem, place the POWER ON switch on the modem back panel to the ON position. The **PWR** LED on the front panel goes ON.

Powering-off the Modem

To turn off power to the modem, place the POWER ON switch on the modem back panel to the OFF position. The **PWR** LED on the front panel goes OFF.

Chapter 3

LEDs and Controls

This chapter describes the LEDs and controls on the modem.

Front Panel LEDs

Table 3-1 describes the LEDs on the modem front panel.

Table 3-1. Front Panel LEDs

LED	Status
PWR	ON = power is being supplied to the modem.
TM	ON = the rotary switch is turned to Analog or Digital Loopback, or the switch is in the Test Pattern transmit mode or Self Test mode and no error is detected.
CD	ON = the modem is detecting a valid carrier.
RD	ON = data is being received or receive data line is in a space condition.
RS	ON = the Request-to-Send line from the DTE is ON.
CS	ON = the Clear-to-Send line from the modem is ON.
TD	ON = data to be transmitted is being furnished to the modem.

Front Panel Test Switch

The modem front panel has a five-position rotary switch that lets you select the modem's operating mode. The five switch positions are:

- ❖ **DATA** — use this position for normal data transmissions.
- ❖ **AL** (Analog Loopback) — this position prepares the modem for testing by the local terminal device. The transmitter output of the modem is disconnected from the output coupling transformer and connected to the modem receiver input. See Figure 3-1.
- ❖ **DL** (Digital Loopback) — this position configures the modem to loop back received data to the transmitter and transmit the data to the remote end. The RS-232-C interface to the terminal is not active during this test. See Figure 3-2.
- ❖ **ST** (Self Test) — this position inhibits the modem from transmitting and receiving data on the COMM LINE. The RS-232-C interface to the terminal is not active during this test. See Figure 3-3.

The test pattern (dot pattern) passes through the transmitter, loops back into the receiver, is demodulated, and is checked for errors. If errors occur, the **TM** LED turns OFF and remains OFF for a period of time that depends on the pattern generator baud rate.

In Analog Loopback and Self Test modes, the received analog data is buffered, amplified by 16 dB (if output level is set to 0 dB), and routed out on the transmit analog pair.

- ❖ **TTP** (Transmit Test Pattern) — this setting forces the transmitter on and transmits data from the test generator to the COMM LINE. The RS-232-C interface lines (RTS, CTS, and Transmit Data) to the transmitter are not active. See Figure 3-4.

The **TM** LED goes ON when the receive data is good. If there are errors, or if the received data does not compare with the transmitted data, the **TM** LED goes off. The RS-232-C interface lines to the receiver are active during this mode.

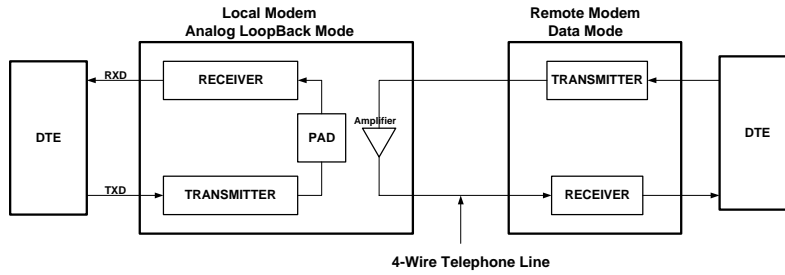

Figure 3-1. Analog Loopback Test

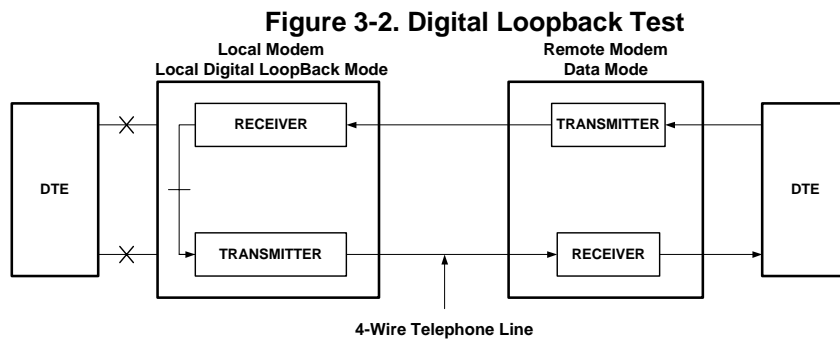

Figure 3-2. Digital Loopback Test

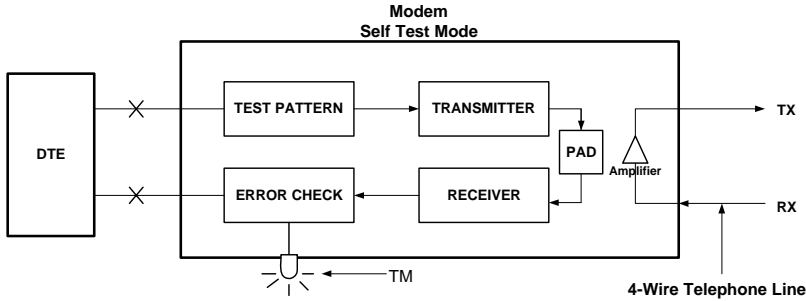

Figure 3-3. Self Test

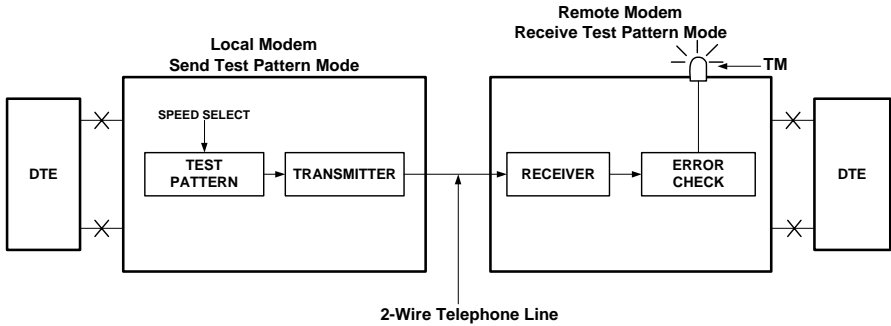

Figure 3-4. Transmit Test Pattern

Chapter 4

Troubleshooting

This chapter describes troubleshooting procedures you can use in the unlikely event you encounter a problem with your modem.

Local Modem Test

The local modem test verifies the local modem's transmitter, receiver, and connection to the locally attached DTE. This test can be run either by generating a data pattern from the locally attached DTE or by having the modem generate a test pattern.

The following procedure describes how to run the local modem test using a locally attached DTE to generate a data pattern.

1. Using the front panel test switch, place the modem in Analog Loopback mode.
2. Turn on the Request To Send line.
3. Use the locally attached DTE to transmit the data pattern and check for data errors on the Receive Data line.

The following procedure describes how to run the local modem test using the modem test pattern instead of a data pattern originated by the local DTE.

1. Using the front panel test switch, place the modem in Self Test mode.
2. The **TM** indicator should turn ON. If the indicator turns OFF or flashes, errors are occurring.

Line and Modem Test

The line and modem test verifies the local modem, the remote modem, and the communications line between them. With this test, the local modem loops back received data to the transmitter and transmits the data to the remote modem. These characters can originate either from a locally attached DTE or by having the modem generate a test pattern.

The following procedure describes how to run the line and modem test using a locally attached DTE to generate a data pattern.

1. Place the remote modem in Digital Loopback mode.
2. Place the local modem in Data mode and transmit a data pattern. Check for data errors on the Receive Data line

The following procedure describes how to run the line and modem test using the modem test pattern instead of a data pattern originated by the local DTE.

1. Place the remote modem in Remote Test mode.
2. Place the local modem in Remote Self Test mode. The **TM** LED should turn ON and remain ON if the data is error free.

Chapter 5

Specifications

This chapter lists the specifications for the modem.

General

Operation:	2-wire half-duplex or 4-wire full-duplex private line operation.
Data rate:	0-1200 bps asynchronous on worst case line. 0-1800 asynchronous on C2 conditioned line
Modulation:	Phase coherent. Frequency Shift Keyed (FSK)
Carrier frequencies:	Mark 1200 Hz $\pm 1\%$ Space 2200 Hz $\pm 1\%$
Line impedance:	600 ohms $\pm 10\%$ transformer coupled and transient protected.
Transmitter output level:	Selectable from 0 to -14 dBm, in 2 dB steps.
RTS-CTS delay:	8, 33, 59, or 219 ms
Carrier Detect delay:	6 or 23 ms OFF-to-ON, 6 On-to-OFF
Digital interface:	EIA RS-232-C and CCITT V.24.
Package:	Standalone
Turnaround squelch:	8 ms or 159 ms
Anti-streaming:	Option to turn transmitter OFF after selected time, even if RTS is ON

Specifications

Test features: Self Test, Analog Loopback, Digital Loopback, and Test Pattern Transmit

Dimensions and Weight

Width: 7.00 inches (17.8 cm)

Length: 9.60 inches (24.4 cm)

Height: 2.25 inches (5.7 cm)

Temperature Range

Operating: -40 to +85 degrees Celsius

Storage: -40 to +85 degrees Celsius

Humidity range: 95% relative, non-condensing

Power Requirements

❖ 115 VAC + or - 10%: 50/60 Hz

❖ 230 VAC + or - 10%: 50/60 Hz

❖ 12 to 60 VDC

For applicable models.

Interface Pin Assignments

DTE Connector - EIA RS-232-C

Pin	RS-232C Circuit	CCITT V.24 Circuit	Function
1	AA	101	Protective Ground
2	BA	103	Transmitter Data
3	BB	104	Receive Data
4	CA	105	Request to Send
5	CB	106	Clear to Send
6	CC	107	Data Set Ready
7	AB	102	Signal Ground
8	CF	109	Data Carrier Detect
9	—	—	+12 Volts Test Only
10	—	—	-12 Volts Test Only
25	—	—	Analog Loopback

Note: All interfaces on the RS-232-C digital connector conform to the requirements of EIA-RS-232-C.

Telco Connector

Pin	Description
4, 5	2-wire mode: transmit/receive pair. 4-wire mode: transmit pair.
3, 6	Receive pair for 4-wire mode.
Polarity of transmit pair or receive pair is not significant. Remaining pins are not used.	

Specifications

NOTES

Appendix A

Compliances

FCC Rule

This device complies with Part 15A of the FCC Rules. Operation is subject to the following two conditions: (1) this device may not cause harmful interference, and (2) this device must accept any interference received, including interference that may cause undesired operation.

This equipment has been tested and found to comply with the limits for a Class A digital device, pursuant to Part 15A of the FCC Rules. These limits are designed to provide reasonable protection against harmful interference in a residential installation. This equipment generates, uses, and can radiate radio frequency energy and, if not installed and used in accordance with the instructions, may cause harmful interference to radio communications. However, there is no guarantee that interference will not occur in a particular installation. If this equipment does cause harmful interference to radio or television reception, which can be determined by turning the equipment off and on, the user is encouraged to try to correct the interference by one or more of the following measures:

- ❖ Reorient or relocate the receiving antenna.
- ❖ Increase the separation between the equipment and the receiver.
- ❖ Connect the equipment to an outlet on a circuit other than the one to which the receiver is connected.
- ❖ Consult the dealer or an experienced radio/TV technician for help.

If none of these actions resolves the problem, consult your distributor or an experienced radio/television technician for additional suggestions.

Additionally, Section 15.838, paragraph d), of the FCC Rules and Regulations states: “Where special accessories, such as shielded cables, are required in order to meet FCC regulations, shielded cables must be used with this equipment. Operation with non-approved equipment or unshielded cables is likely to result in interference to radio and TV reception. The user is cautioned that changes and modifications to this equipment without the approval of the manufacturer could void the user’s authority to operate this equipment.

Compliances

Department of Canada Statement

This Class A digital apparatus meets all requirements of the Canadian Interference-Causing Equipment Regulations.

Cet appareil numérique de la classe A respecte toutes les exigences du Règlement sur le matériel brouilleur du Canada.

Appendix B

Limited Product Warranty

Raymar Information Technology, Inc. Limited Warranty

One Year Limited Hardware Warranty

Raymar Information Technology, Inc., dba Raymar-Telenetics, warrants their products against defects in hardware, material and workmanship under normal use for one (1) year from the date of purchase. Raymar will, at no charge, either repair the product (with new or reconditioned parts), or replace it (with a new or reconditioned product). Repaired replacement products are warranted for either 90 days or the remainder of the original warranty period, whichever is longer. This warranty extends to the original end-user only.

What This Warranty Does Not Cover

This warranty does not cover: (a) software; (b) installation or service of the product; (c) conditions resulting from consumer damage such as improper maintenance or misuse, abuse, accident or alteration; (d) all plastic surfaces (including display screens) and all other exposed parts that are scratched or damaged due to normal use; (e) operation of our products with equipment not supplied by Raymar (f) products which have had the serial number removed or made illegible; or (g) products rented to others. This warranty applies only to hardware products manufactured by or for Raymar Information Technology, Inc. and identified by the Raymar-Telenetics trademark, trade name or product identification logo affixed to them. Refer to the Service and Support section of the User's Guide for service after the warranty expires. No warranty is made as to coverage availability or grade of service provided by the carrier.

General Provisions

This warranty sets forth Raymar's entire hardware responsibilities regarding this product. Repair, replacement or refund of the purchase price is at Raymar's discretion. THIS WARRANTY IS GIVEN IN LIEU OF ALL OTHER EXPRESS WARRANTIES, IMPLIED WARRANTIES, INCLUDING WITHOUT LIMITATION IMPLIED WARRANTIES OF MERCHANTABILITY AND FITNESS FOR A PARTICULAR PURPOSE, AND ARE LIMITED TO THE DURATION OF THIS LIMITED WARRANTY. IN NO EVENT SHALL RAYMAR BE LIABLE FOR DAMAGES IN EXCESS OF THE PURCHASE PRICE OF THE PRODUCT, FOR ANY LOSS OF USE, LOSS OF TIME, INCONVENIENCE,

Limited Product Warranty

COMMERCIAL LOSS, LOST PROFITS OR SAVINGS, OR OTHER INCIDENTAL, SPECIAL OR CONSEQUENTIAL DAMAGES ARISING OUT OF THE USE OR INABILITY TO USE THIS RAYMAR PRODUCT, TO THE FULL EXTENT SUCH MAY BE DISCLAIMED BY LAW. WITHOUT LIMITING THE FOREGOING, RAYMAR SHALL HAVE NO LIABILITY FOR ANY DATA STORED IN OR USED WITH THE PRODUCT, INCLUDING THE RECOVERY COSTS OF SUCH DATA OR PROGRAMS.

State Law Rights

SOME STATES DO NOT ALLOW THE EXCLUSION OR LIMITATION OF INCIDENTAL OR CONSEQUENTIAL DAMAGES OR LIMITATIONS ON HOW LONG AN IMPLIED WARRANTY LASTS. THE ABOVE LIMITATIONS OR EXCLUSIONS MAY NOT APPLY TO YOU. This warranty gives you specific legal rights, and you may also have other rights which vary from State to State.

Provincial Law Rights

SOME PROVINCIAL LAWS DO NOT ALLOW THE EXCLUSION OR LIMITATION OF IMPLIED WARRANTIES, THE EXCLUSION OR LIMITATION OF WARRANTY COVERAGE IN CERTAIN SITUATIONS. SOME OF THE ABOVE LIMITATIONS OR EXCLUSIONS CONTAINED IN THIS LIMITED WARRANTY MAY NOT APPLY TO YOU. This warranty gives you specific rights, and you may have other rights which vary from province to province.

How To Use Raymar's Limited Warranty Service

To take advantage of this warranty, you must do the following:

- If you are having trouble with your product, contact Raymar service using the appropriate number from the Service and Support section of the User's Guide. If it is determined that your product requires service, you will be issued a Return Materials Authorization (RMA) form.
- Pack the defective product securely for shipping. Include only the units pre-approved by service on your RMA form.
- This warranty is void if the product is damaged in transit, you must insure your shipment.
- Ship the defective product, proof of date of purchase, and the RMA form to the address specified.
- Display your RMA number prominently on the outside of the shipping box. Customer is responsible for freight in, door to door. Raymar is responsible for return shipping costs.
- To ensure prompt service, please write on the RMA form a brief description of the problem you are experiencing with the product.

Raymar Information Technology, Inc.

7325 Roseville Road

Sacramento, CA 95842

Service Hotline (800) 747-1522

<http://support.telenetics.com> or e-mail to techsupport@raymarinc.com

Appendix C

RMA Procedure

Return Merchandise Authorization (RMA) Procedure

Before returning any Raymar-Telenetics product, an RMA number must be obtained.

Before asking for an RMA number, ascertain that the product was purchased from Raymar-Telenetics. If you bought the product from a Distributor or Systems Integrator, the product should be returned to that vendor.

The most convenient method to obtain an RMA number for a product purchased from Raymar-Telenetics is to call 1-800-747-1522.

Please have the required information ready:

Your Company Name, billing address and the return address that we would use to return the product to you. Please include any Mail Stop or specific delivery information. The City, State, and Zip code are all required. Your phone number, Fax number and email address.

For each item you wish to return: List the product model number, the serial number for each item you wish to return, a description of the problem you are encountering, and the cause of the problem (if known).

A product support specialist may call to verify that the product is properly installed or may ask you to perform tests to insure that the product has actually failed.

The product must be properly packed and returned to:

Raymar-Telenetics
7325 Roseville Road
Sacramento, CA 95842

The RMA number must be legibly displayed on the shipping carton.

No RMA's will be issued without a product review; Raymar-Telenetics will not be responsible for any product returned without an RMA number.

If the product is out of warranty, please let us know your method of payment for repairs, either a Purchase Order, or Credit Card on the RMA request. Repairs currently require 5 – 10 working days, and are returned UPS Ground.