

**Installation, Operation & Diagnostics**

for the

**PE14.4L & PE9.6L**

**Pony Express Modem Modules**



**Raymar Information Technology, Inc.**

7325 Roseville Road  
Sacramento, CA 95842  
800-695-1951  
Fax: 916-783-1952

The products and programs described in this User's Guide are licensed products of Raymar-Telenetics. This User's Guide contains proprietary information protected by copyright, and this User's Guide and all accompanying hardware and documentation are copyrighted.

Raymar-Telenetics does not warrant that the hardware will work properly in all environments and applications, and makes no warranty and representation, either implied or expressed, with respect to the quality, performance, merchantability, or fitness for a particular purpose.

Information in this User's Guide is subject to change without notice and does not represent a commitment on the part of Raymar-Telenetics. Raymar-Telenetics assumes no responsibility for any inaccuracies that may be contained in this User's Guide.

Raymar-Telenetics makes no commitment to update or keep current the information in this User's Guide, and reserves the right to make changes to this User's Guide and/or product without notice.

No part of this manual may be reproduced or transmitted in any form or by any means, electronic or mechanical, including photocopying, recording, or information storage and retrieval systems, for any purpose other than the purchaser's personal use, without the express written permission of Raymar-Telenetics.

© Copyright 2010 Raymar Information Technology, Inc.  
7325 Roseville Road  
Sacramento, California 95842  
Tel: 800-695-1951 Direct: +1-916-783-1951  
Fax: 916-783-1952  
Web site: [www.raymarinc.com](http://www.raymarinc.com)

## TABLE of CONTENTS

1. STANDARDS .....	Page 1
2. PRODUCT OVERVIEW .....	Page 1
3. GENERAL PRODUCT SPECIFICATIONS.....	Page 1
4. MODEM SPECIFICATIONS.....	Page 2
5. ANALOG INTERFACE SPECIFICATIONS .....	Page 3
6. ANALOG MICROWAVE SPECIFICATIONS ..	Page 4
7. CONNECTOR PIN-OUTS .....	Page 6
8. OUTLINE DRAWING .....	Page 7
9. MODEM CONFIGURATION.....	Page 8
10.FACTORY CONFIGURARION .....	Page 9
11.AT COMMAND SET & S-REGISTERS .....	Page 11
12.DIAGNOSTICS .....	Page 22

## 1. STANDARDS

Meets FCC Rules Part J, Subpart 15, Class A for radiated emissions.

## 2. PRODUCT OVERVIEW

The PE14.4L & PE9.6L Modem Modules are industrial grade V.32bis & V.22bis modems, respectively, for connection to unconditioned and conditioned, voice grade, type 3002 two or four-wire leased lines. They are powered from 5.5 to 9VDC unregulated or +5VDC regulated, are surge protected on the analog and digital connections, and will operate in temperatures from -40 to +85 deg C.

These modules are supplied to OEMs for integration into relays, controllers, RTUs, etc. The data interface can be either RS232 or TTL.

A PE14.4L or PE9.6L is also at the heart of all Raymar-Telenetics V.32bis and V.22bis end-user products such as the MIU14.4L and MIU9.6L standalone modems and the **Myriad** MD14.4L & MD9.6L rack mount modems.

## 3. GENERAL PRODUCT SPECIFICATIONS

**Dimensions:** See Section 10

### Voltage Supply, Data Interface & Current Requirements:

Model No.	Voltage	Data Interface	Current
PE14.4L-D0	+5.5 to 9VDC	RS232	150mA
PE14.4L-D1	+5.5 to 9VDC	TTL	135mA
PE14.4L-D2	+5VDC $\pm$ 5%	RS232	150mA
PE14.4L-D4	+5VDC $\pm$ 5%	TTL	135mA
PE9.6L-D0	+5.5 to 9VDC	RS232	90mA
PE9.6L-D1	+5.5 to 9VDC	TTL	65mA
PE9.6L-D2	+5VDC $\pm$ 5%	RS232	90mA
PE9.6L-D4	+5VDC $\pm$ 5%	TTL	65mA

**Surge Protection:** Analog Line: PE9.6L = 3.75kVAC  
PE14.4L = 5kVAC  
Digital Line: ESD  $\pm$  10kV

**Operating Temperature:** -40 to +85 deg C

**Operating Humidity:** 0 to 90% (non-condensing.)

**Storage Temperature:** -55 to 100 deg C

## 4. MODEM SPECIFICATIONS

The PE9.6L & PE14.4L designs are based on the Rockwell modem chipsets. Modem control is through the industry standard 'AT' command set. The PE9.6L & PE14.4L provide all popular error correction and data compression capabilities. The PE9.6L & PE14.4L provide the following modem features.

### Data Command Set

Rockwell AT command set (See Section 11)

### Data Modulations and Speeds

PE Module	Modulation	Type	Sync/Async	Data Rate (bps)
PE14.4L	V.32bis	TCM	Async	14400, 1200, 9600, 7200
PE14.4L	V.32	TCM	Async	9600, 4800
PE14.4L	V.33/V.17	TCM	Sync	14400, 1200, 9600, 7200
PE14.4L	V.29	QAM	Sync	9600, 7200, 4800
PE14.4L	V.27	QAM	Sync	4800, 2400
PE14.4L PE9.6L	V.22bis	QAM	Async	2400, 1200
PE14.4L PE9.6L	V.22	PSK	Async	1200, 600
PE14.4L PE9.6L	V.21	FSK	Async	0 – 300
PE14.4L PE9.6L	Bell212A	PSK	Async	1200
PE14.4L PE9.6L	Bel103J	FSK	Async	0 - 300

### Data Modulation Connectivity:

95% or better with Receive Signal Level at -40dBm and Signal/Noise Ratio 20dB (PE14.4L) or 18dB (PE9.6L)

### Error Correction and Data Compression:

Error Correction: MNP Class 2-4, MNP 10, V.42.

Data Compression: MNP 5, V.42bis.

### Serial Formats and Flow Control:

Serial Speeds: PE14.4L: 57600, 38400, 19200, 14400, 9600, 4800, 2400, 1200, 300bps  
PE9.6L: 9600, 4800, 2400, 1200, 300bps

Serial Formats: 8N1, 8E1, 801, 7E1, 7O1, 7N2

Flow Control: RTS/CTS (hardware);  
XON/XOFF (software);  
None

**Telephone Analog:**

Tx Output Level: -10 dBm  $\pm$  1.0 dB  
Rx Sensitivity: - 43dBm  
Termination: 2 wire switched line network  
Line Impedance: 600 / 900 ohms balance

**Other Features:**

Receiver Equalization Automatic Adapter and Compromise Equalization with 18 to 32 receiver Tap Coefficients.  
Remote Commands Through MNP or Sequenced modes  
Self Test Diagnostics Local Analog Loopback (LALB), Local Digital Loopback (LDLB), Remote Digital Loopback (RDLB) and Self Test in LALB & RDLB

**5. ANALOG INTERFACE SPECIFICATIONS**

The PE9.6L & PE14.4L contain analog circuitry for connection to the public conditioned or unconditioned, Bell type 3002, 2 or 4-wire, full duplex voice grade lines. The PE9.6L & PE14.4L will also interface to Power Line Carrier or Microwave radio voice channel networks.

The PE9.6L & PE14.4L have an RJ-11 terminated connector. The following lists the PE9.6L & PE14.4L analog interfaces

**Analog Line Type:**

Conditioned or unconditioned, Bell type 3002, 2 or 4-wire, full duplex voice grade lines or better.

**Analog Line Specifications:**

Bandwidth 300 Hz to 3400 Hz ( $\pm$ 3dB)  
Impedance 600 / 900 ohms, balanced  
Frequency Response 400 to 3000Hz ( $\pm$ 2dB)  
Receiver Input Level -16dBm max.  
Output Level +7 dBm  
Noise Signal Level -48 dBmO

**Polarity:** None. The PE9.6L & PE14.4L's analog circuitry is insensitive to the analog line's polarity.

## 6. ANALOG MICROWAVE INTERFACE

The PE9.6L & PE14.4L are designed to interface to a Microwave radio voice channel network with the following specifications:

Phase Jitter (10 to 300Hz)	1 degree peak-to-peak, max.
Frequency Response:	300 - 3400Hz -3, +0.7 dB 400 - 3000Hz -1, +0.7 dB 600 - 2400Hz $\pm$ 0.7 dB
Frequency Stability:	With Synchronization 0.1Hz Without Synchronization 0.5 Hz / month
Level Stability (w/o regulation):	$\pm$ 0.5 dB (6 months)
Harmonic Distortion:	1% max, 0.3 % typical (1 KHz, 0 dBmO test tone)
Absolute Delay:	Option – 001: 1500 $\mu$ sec, maximum Option – 002: 1900 $\mu$ sec, maximum
Group Delay (option - 001):	600 - 3200 Hz 1200 $\mu$ sec, maximum 800 - 2800 Hz 550 $\mu$ sec, maximum 1000-2600 Hz 350 $\mu$ sec, maximum
Group Delay (option - 002):	600 - 3200 Hz with 1000 $\mu$ sec, maximum 800 - 2800 Hz with 400 $\mu$ sec, maximum 1000-2600 Hz with 180 $\mu$ sec, maximum
Linearity:	0.3 dB +3.5 dBmO
Limiting:	+7.5dBmO, max (+6.5 dBmO typical) for +20dBmO input
Crosstalk (intelligible) (1 KHz test tone at 0 dBmO):	
Inter-channel	65 dBmO maximum, 80 dBmO typical
Intra-channel	70 dBmO maximum

Crosstalk (unintelligible):

Adjacent channel 28dBrc0 maximum (24 455B weighted noise at 0 dBmO dBrc0 typical).

Intra-channel 28 dBrc0, maximum (18 dBrc0, typical)  
(1 KHz test tone at 0 dBmO)

Out of Band Signalling: Frequency 3825 Hz  
Level -20 dBmO  
Pulse speed (30 to 80% break) 8 to 14 pps  
Pulse distortion  $\pm 3$  dB, level var. 3% max.  
Signaling leak -60 dBmO, maximum

## 7. CONNECTOR PIN-OUTS

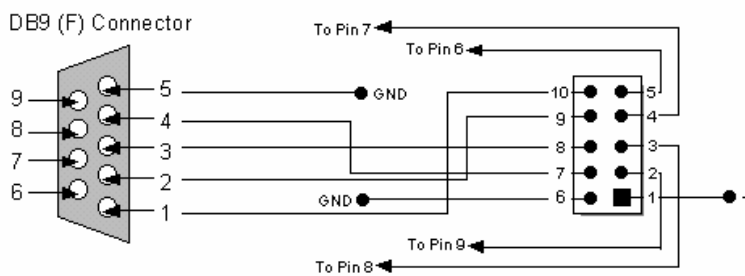
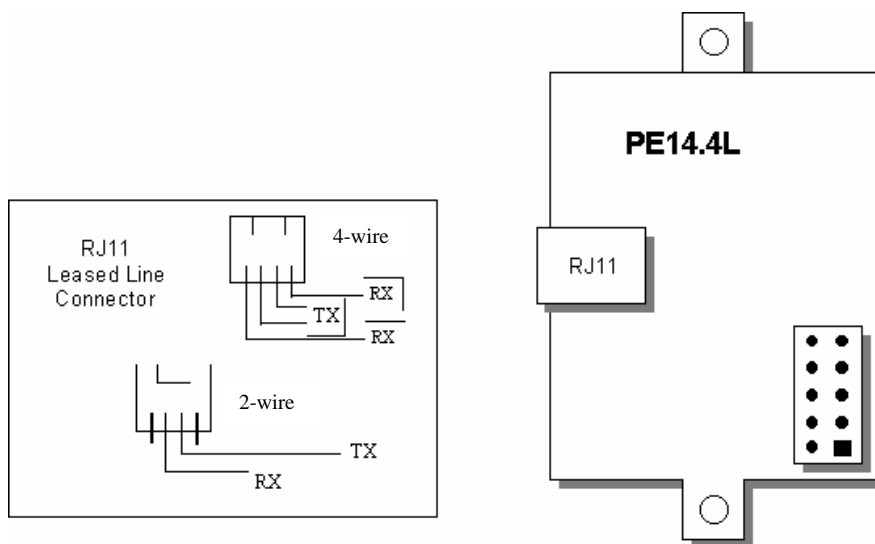

### Connecting Power to your PE9.6L & PE14.4L

The DC supply voltage is connected to Pins 1 & 6 of the 10-pin header. With your PE evaluation unit you have a ribbon cable to connect the header to a DB9 connector. The two flying leads are connected to header Pins 1 & 6 for power connection.

<b>Pin 10</b> <b>CD</b>	<b>Pin 5</b> <b>DSR</b>
<b>Pin 9</b> <b>RxD</b>	<b>Pin 4</b> <b>RTS</b>
<b>Pin 8</b> <b>TxD</b>	<b>Pin 3</b> <b>CTS</b>
<b>Pin 7</b> <b>DTR</b>	<b>Pin 2</b> <b>RI</b>
<b>Pin 6</b> <b>Ground</b>	<b>Pin 1</b> <b>+ Power</b>

## 8. OUTLINE DRAWING

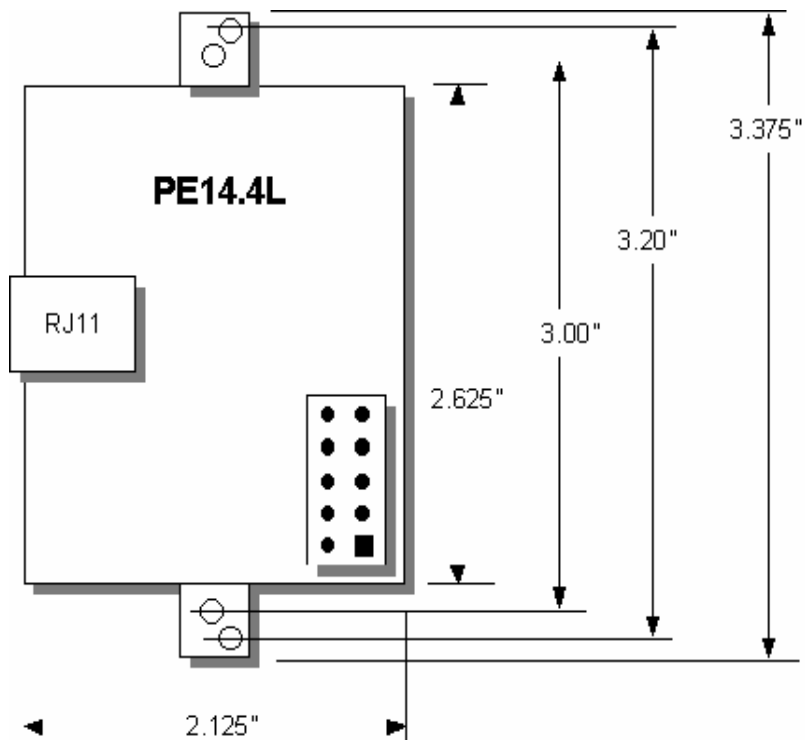

## 9. MODEM CONFIGURATION

Raymar-Telenetics leased line modems are based upon Rockwell chipsets. These chipsets contain Rockwell's "AT" command set.

Unless otherwise specified at the time of order, your modem will have left the Raymar-Telenetics factory in the configuration detailed on the following pages.

- (a) The Raymar-Telenetics factory configuration differs from the Rockwell default configuration as follows:

&C0 Rockwell Default	Carrier Detect (CD) always ON.
&C1 Raymar-Telenetics Factory	Carrier Detect (CD) only ON when modem connected (off hook)

- (b) Raymar-Telenetics has modified the following Rockwell command:

&R0 Rockwell Default	CTS follows RTS with a 1ms - 5ms delay
&R0 Raymar-Telenetics Modification	CTS follows RTS with no delay.

- (c) Raymar-Telenetics has added the following new AT Command to the PE14.4L:

### **Dumb Mode Feature (\S0, \S1)**

In Dumb Mode, the modem will not respond to any received data, including AT commands. Dumb mode is useful if there is any possibility that a device connected to the modem will try to send data while the modem is in its connect sequence (such data will abort the connection sequence).

A password must be entered prior to using Dumb Mode. Modems are shipped without a password. To record a password, enter AT&Z3=password&W<enter> (substitute your preference for "password", it is case sensitive).

To enter dumb mode, type ATpassword<enter>, followed by AT\S1<enter>. (This entire sequence must be entered within 10 seconds).

To exit dumb mode there are two possible methods:

1. Enter ATpassword<enter>, then AT\S0<enter>, within 10 seconds.
2. Power modem off, power on, you have 20 seconds to enter ATpassword<enter>, then AT\S0<enter>

## General

You can review the configuration of your modem by entering AT&V  
<enter>.

You can restore the Rockwell factory configuration by entering  
AT&F&W

## 10. FACTORY CONFIGURATION ~ PE9.6L & PE14.4L

### ACTIVE PROFILE:

```
B1 E1 L1 M1 N1 Q0 T V1 W0 X4 Y0 &C1 &D2 &G0 &J0 &K3
&Q5 &R1 &S0 &T5 &X0 &Y0 S00:001 S01:000 S02:043 S03:013
S04:010 S05:008 S06:002 S07:050 S08:002 S09:006 S10:014
S11:095 S12:050 S18:000 S25:005 S26:001 S36:007 S37:000
S38:020 S44:020 S46:138 S48:007 S95:000
```

### STORED PROFILE 0:

```
B1 E1 L1 M1 N1 Q0 T V1 W0 X4 Y0 &C1 &D2 &G0 &J0 &K3
&Q5 &R1 &S0 &T5 &X0 S00:001 S02:043 S06:002 S07:050
S08:002 S09:006 S10:014 S11:095 S12:050 S18:000 S36:007
S37:000 S40:168 S41:195 S46:138 S95:046
```

### STORED PROFILE 1:

```
B1 E1 L1 M1 N1 Q0 T V1 W0 X4 Y0 &C1 &D2 &G0 &J0 &K3
&Q5 &R1 &S0 &T5 &X0 S00:001 S02:043 S06:002 S07:050
S08:002 S09:006 S10:014 S11:095 S12:050 S18:000 S36:007
S37:000 S40:168 S41:195 S46:138 S95:000
```

### TELEPHONE NUMBERS:

```
0=          1=
2=          3=
```

**IMPORTANT NOTE  
regarding  
AT COMMANDS  
for  
LEASED LINE MODEMS**

Applicable Modems: PE2496L Modem Module  
 PE14.4L Modem Module  
 MIU9.6L Standalone Modem  
 MIU14.4L Standalone Modem  
*Myniad* MDR/PE9.6L Modem Bank  
*Myniad* MDR/PE14.4L Modem Bank  
 Zodiac ZDR/MultiPort14.4L Modem

Your modem has left our factory in the "command" mode and needs to be configured for leased line operation using the following suggested command string...

**AT&C1E0Q1&D0\M0 (or \M1, SEE BELOW) \H1&W**

&C = CD True  
 E0 = Disables Echo  
 Q1 = Disables Result Codes  
 &D0 = Ignores DTR if DTR not used  
 \M0 = "Local" modem\*  
 \M1 = "Remote" modem\*  
 \H1 = Leased Line Mode  
 &W = Save

\* For each pair of modems, configure one as the "Local" and the other as the "Remote".

If you wish to reconfigure the modem at a later date, return to the command mode as follows...

1. Disconnect power to modem
2. Reconnect power to modem
3. WITHIN 15 SECONDS type AT\H0<enter>
4. Modem is now in command mode
5. Type new configuration
6. Finish new configuration with \H1&W<enter>

## 11. AT COMMAND SET and S-REGISTERS

Raymar-Telenetics leased line modems are based upon Rockwell chipsets. These chipsets contain Rockwell's "AT" command set.

A summary of the Rockwell command set for the **PE9.6L** and **PE14.4L** *Pony Express™* modem modules is provided on the following pages.

A *Pony Express™* Modem Module is at the heart of all Raymar-Telenetics modems, including the following...

<b>MIU9.6L</b> .....	<b>PE9.6L</b>
<b>MIU14.4L</b> .....	<b>PE14.4L</b>
<b>MIU/PowerPort9.6L</b> .....	<b>PE9.6L</b>
<b>MIU/PowerPort14.4L</b> .....	<b>PE14.4L</b>
<b>Myriad MD9.6L</b> .....	<b>PE9.6L</b>
<b>Myriad MD14.4L</b> .....	<b>PE14.4L</b>

Contact Raymar-Telenetics for more detailed information on AT Commands and S-Registers.

### SUMMARY OF THE ROCKWELL "AT" COMMAND SET

To communicate using the modem, use an asynchronous communication program. The command set for the Raymar-Telenetics modems is compatible with the Hayes command set.

The modem is controlled and configured by the AT (attention command). Each command consists of the following elements (with the exception of the A/ and the +++ command that will be discussed later).

1. The two character sequence AT
2. A command
3. A command parameter
4. A carriage return

A command is not entered until a carriage return <ENTER> is entered. Spaces entered are ignored. For example, to enter the command 'Answer', type ATA and <ENTER>.

Some commands do not have parameters. Any missing parameters in a command are assigned the value zero, which may be a valid parameter for the command. The sequence followed by AT command causes the modem to enter a command state. That is, AT without a command serves as a wake up code and an "OK" appears on the screen.

The modem queues commands in a 40-character command line. The command line begins with AT and can have several commands. A separator is not required between the commands.

The command line format is the "AT" prefix, followed by the required commands from the attached list and terminated with a Carriage Return.

When a carriage return is received, the commands are performed in the order in which they are sent to the modem. If more than 40 characters are sent to the modem, an error occurs and all commands must be re-entered.

## BASIC AT COMMANDS for the PE9.6L & PE14.4L MODEM MODULES

Command	Function
A/	Re-execute command.
A	Go off-hook and attempt to answer a call.
B0	Select V.22 connection at 1200 bps.
B1	Select Bell 212A connection at 1200 bps.
C1	Return OK message.
Dn	Dial modifier.
E0	Turn off command echo.
E1	Turn on command echo.
F0	Select auto-detect mode (equivalent to N1).
F1	Select V.21 or Bell 103.
F2	Reserved.
F3	Select V.23 line modulation.
F4	Select V.22 or Bell 212A 1200 bps line speed.
F5	Select V.22 bis line modulation.
F6	Select V.32 bis or V.32 4800 line modulation (PE14.4L)
F7	Select V.32 bis 7200 line modulation.
F8	Select V.32 bis or V.32 9600 line modulation.
F9	Select V.32 bis 12000 line modulation.
F10	Select V.32 bis 14400 line modulation.
H0	Initiate a hang-up sequence.
H1	If on-hook, go off-hook and enter command mode.
I0	Report product code.
I1	Report pre-computed checksum.
I2	Report OK.
I3	Report firmware revision, model, and interface type.
I4	Report response "Telenetics Inc. Rev"
I5	Report the country code parameter.
I6	Report modem data pump model and code revision.
I7	Reports the DAA code
L0	Set low speaker volume.
L1	Set low speaker volume.
L2	Set medium speaker volume.
L3	Set high speaker volume.

M0	Turn speaker off.
M1	Turn speaker on during handshaking and turn speaker off while receiving carrier.
M2	Turn speaker on during handshaking and while receiving carrier.
M3	Turn speaker off during dialing and receiving carrier and turn speaker on during answering.
N0	Turn off automode detection.
N1	Turn on automode detection.
O0	Go on-line.
O1	Go on-line and initiate a retrain sequence.
P	Force pulse dialing.
Q0	Allow result codes to DTE.
Q1	Inhibit result codes to DTE.
Sn	Select S-Register as default.
Sn?	Return the value of S-Register n.
=v	Set default S-Register to value v.
?	Return the value of default S-Register.
T	Force DTMF dialing.
V0	Report short form (terse) result codes.
V1	Report long form (verbose) result codes.
W0	Report DTE speed in EC mode.
W1	Report line speed, EC protocol and DTE speed.
W2	Report DCE speed in EC mode.
X0	Report basic call progress result codes, i.e., OK, CONNECT, RING, NO CARRIER (also, for busy, if enabled, and dial tone not detected), NO ANSWER and ERROR.
X1	Report basic call progress result codes and connections speeds (OK, CONNECT, RING, NO CARRIER (also, for busy, if enabled, and dial tone not detected), NO ANSWER, CONNECT XXXX, and ERROR.
X2	Report basic call progress result codes and connections speeds, i.e., OK, CONNECT, RING, NO CARRIER (also, for busy, if enabled, and dial tone not detected), NO ANSWER, CONNECT XXXX, and ERROR.
X3	Report basic call progress result codes and connection rate, i.e., OK, CONNECT, RING, NO CARRIER, NO ANSWER, CONNECT XXXX, BUSY, and ERROR.
X4	Report all call progress result codes and connection rate, i.e., OK, CONNECT, RING, NO CARRIER, NO ANSWER, CONNECT XXXX, BUSY, NO DIAL TONE and ERROR.

Y0	Disable long space disconnect before on-hook.
Y1	Enable long space disconnect before on-hook.
Z0	Restore stored profile 0 after warm reset.
Z1	Restore stored profile 1 after warm reset.
&C0	Force RLSD active regardless of the carrier state.
&C1	Allow RLSD to follow the carrier state.
&D0	Interpret DTR ON-to-OFF transition per &Qn: &Q0, &Q5, &Q6 The modem ignores DTR. &Q1, &Q4 The modem hangs up. &Q2, &Q3 The modem hangs up.
&D1	Interpret DTR ON-to-OFF transition per &Qn: &Q0, &Q1, &Q4, &Q5, &Q6 Asynchronous escape. &Q2, &Q3 The modem hangs up.
&D2	Interpret DTR ON-to-OFF transition per &Qn: &Q0 through &Q6 The modem hangs up.
&D3	Interpret DTR ON-to-OFF transition per &Qn: &Q0, &Q1, &Q4.  &Q5, &Q6 The modem performs soft reset. &Q2, &Q The modem hangs up.
&F0	Restore factory configuration 0.
&F1	Restore factory configuration 1.
&G0	Disable guard tone.
&G1	Disable guard tone.
&G2	Enable 1800 Hz guard tone.
&J0	Set S-Register response only for compatibility.
&J1	Set S-Register response only for compatibility.
&K0	Disable DTE/DCE flow control.
&K3	Enable RTS/CTS DTE/DCE (Hardware) flow control.
&K4	Enable XON/XOFF DTE/DCE (Software) flow control.
&K5	Enable transparent XON/XOFF flow control.
&K6	Enable both RTS/CTS and XON/XOFF flow control.
&L0	Select dial up line operation.
&L1	Select leased line operation.

\* Serial interface operation only.

&M0	Select direct asynchronous mode.
&M1	Select sync connect with async off-line command mode. *
&M2	Select sync connect with async off-line command mode and enable DTR dialing of directory zero. *
&M3	Select sync connect with async off-line command mode and enable DTR to act as Talk/Data switch. *
&P0	Set 10 pps pulse dial with 39%/61% make/break.
&P1	Set 10 pps pulse dial with 33%/67% make/break.
&P2	Set 20 pps pulse dial with 39%/61% make/break.
&P3	Set 20 pps pulse dial with 33%/67% make/break.
&Q0	Select direct asynchronous mode.
&Q1	Select sync connect with Async off-line command mode. *
&Q2	Select sync connect with Async off-line command mode and enable DTR dialing of directory zero. *
&Q3	Select sync connect with Async off-line command mode and enable DTR to act as Talk/Data switch. *
&Q4	Select Hayes AutoSync mode.
&Q5	Modem negotiates an error-corrected link.
&Q6	Select asynchronous operation in normal mode.
&R0	CTS tracks RTS (Async) or acts per V.25 (sync).
&R1	CTS is always active.
&S0	DSR is always active.
&S1	DSR acts per V.25.
&T0	Terminate any test in progress.
&T1	Initiate local analog loopback.
&T2	Returns ERROR result code.
&T3	Initiate local digital loopback.
&T4	Allow remote digital loopback.
&T5	Disallow remote digital loopback request.
&T6	Request an RDL without self-test.
&T7	Request an RDL with self-test.
&T8	Initiate local analog loop with self-test.
&V	Display current configurations.
&W0	Store the active profile in NVRAM profile 0.
&W1	Store the active profile in NVRAM profile 1.
&X0	Select internal timing for the transmit clock.
&X1	Select external timing for the transmit clock.
&X2	Select slave receive timing for the transmit clock.

&Y0	Recall stored profile 0 upon power up.
&Y1	Recall stored profile 1 upon power up.
&Zn=x	Store dial string x (to 35) to location n (0 to 3 depending upon modem model).
%E0	Disable line quality monitor and auto retrain.
%E1	Enable line quality monitor and auto retrain.
%E2	Enable line quality monitor and fallback/fall forward.
%L	Return received line signal level.
%Q	Report the line signal quality.
\D1	Enable Auto Dial via DTR off to on sequence *PE14400 only
\D0	Disable Auto Dial (default) *PE14400 only
\G0	Disable modem to modem flow control.
\G1	Enable modem to modem flow control.
\H0	Command Mode default
\H1	Lease Line Mode
\Kn	Controls break handling during three states: When modem receives a break from the DTE:
\K0,2,4	Enter on-line command mode, no break sent to the remote modem.
\K1	Clear buffers and send break to remote modem.
\K3	Send break to remote modem immediately.
\K5	Send break to remote modem in sequence with transmitted data.
	When modem receives \B in on-line command state:
\K0,1	Clear buffers and send break to remote modem.
\K2,3	Send break to remote modem immediately.
\K4,5	Send break to remote modem in sequence with transmitted data.
	When modem receives break from the remote modem:
\K0,1	Clear data buffers and send break to DTE.
\K2,3	Send a break immediately to DTE.
\K4,5	Send a break with received data to the DTE.
\M0	Select Answer Mode (Lease Line) with \H1 active
\M1	Select Originate Mode (Lease Line) with \H1 active
\N0	Select normal speed buffered mode.
\N1	Select direct mode.
\N2	Select reliable link mode.
\N3	Select auto reliable mode.
\N4	Force LAPM mode.
\N5	Force MNP mode.
\S0	Unlock command mode (normal mode) *PE14400 only
\S1	Lock (out) command mode (security mode) *PE14400 only

## ECC COMMANDS

%C0	Disable data compression.
%C1	Enable MNP 5 data compression.
%C2	Enable V.42 bis data compression.
%C3	Enable both V.42 bis and MNP 5 compression.
\A0	Set maximum block size in MNP to 64.
\A1	Set maximum block size in MNP to 128.
\A2	Set maximum block size in MNP to 192.
\A3	Set maximum block size in MNP to 256.
\Bn	Send break of n x 100 ms.

## S-Register Summary

Register	Function	Range	Units	Save	Default*
S0	Rings to Auto-Answer	0-255	Rings	*	0
S1	RING COUNTER	0-255	Rings		0
S2	ESCAPE CHARACTER	0-255	ASCII	*	43
S3	Carriage Return Character	0-127	ASCII		13
S4	Line Feed Character	0-127	ASCII		10
S5	Backspace Character	0-255	ASCII		8
S6	Wait time for Dial Tone	2-255	S	*	2
S7	Wait time for Carrier	1-255	s	*	50
S8	Pause Time for Dial Delay Modifier	0-255	s	*	2
S9	Carrier Detect Response Time	1-255	0.1 s	*	6
S10	Carrier Loss Disconnect Time	1-255	0.1 s	*	14
S11	DTMF Tone Duration	50-255	0.01 s	*	95
S12	Escape Code Guard Time	0-255	0.02 s	*	50
S13	Reserved	-	-	-	-
S14	General Bit Mapped	-	-	*	138 (8Ah)
S15	Reserved	-	-	-	-

Register	Function	Range	Units	Save	Default*
S16	Test Mode Bit Mapped option (&T)	-	-	-	0
S17	Reserved	-	-	-	-
S18	Test Timer	0-255	s	*	0
S19-S20	Reserved	-	-	-	-
S21	V.24/General Bits Opt.	-	-	*	4 (04h)
S22	Speaker/Results	-	-	*	117
S23	General Bit Mapped Options	-	-	*	55 (35h)
S24	Sleep Inactivity Timer	0-255	s	*	0
S25	Delay to DTR Off	0-255	s or 0.01 s	*	0
S26	RTS to CTS Delay	0-255	0.01 s		1
S27	General Bit-Mapped Options	-	-	*	73 (49h)
S28	General Bit-Mapped Options	-	-	*	0
S29	Flash Dial Modifier Time	0-255	10ms		0
S30	Disconnect Inactivity Time	0-255	10s		0
S31	General Bit-Mapped Options	-	-	*	2
S32	XON Character	0-255	ASCII		17 (11h)

Register	Function	Range	Units	Save	Default*
S33	XOFF Character	0-255	ASCII		19 (13h)
S34-S35	Reserved	-	-		-
S36	LAPM Failure Control	-	-	*	7
S37	Line Connection Speed	-	-	*	0
S38	Delay before Forced Hang-up	0-255	s		20
S39	Flow Control	-	-	*	3
S40	General Bit-Mapped Options	-	-	*	105 (69)
S41	General Bit-Mapped Options	-	-	*	3
S42-S45	Reserved	-	-		-
S46	Data Compression Control	-	-	*	138
S48	V.42 Negotiation Control	-	-	*	7
S80	Soft-Switch Functions	-	-		0
S82	LAPM Break Control	-	-		128 (40h)
S86	Call Failure Reason Code	0-255	-		-
S95	Result Code Messages Control	-	-	*	0

## 12. DIAGNOSTICS

The following pages provide software and hardware techniques for diagnosing communication problems and thereby isolating the problem at the local modem, the remote modem or the interconnecting line.

The following AT&Tn commands form part of the CCITT V.54 protocol and can be used for diagnostic testing.

Note: &Tn commands can only be used when the modem is configured for &Q0 <CR> (unbuffered/direct asynchronous mode).

### **&T0 TERMINATE TEST IN PROGRESS**

If a V.54 loopback test is in progress as a result of executing an &Tn command, then the &T0 command will cause that test to be terminated, provided that the modem is in the command state or a V.54 state that accepts commands from the DTE. See specific &Tn command descriptions for termination actions.

### **&T1 INITIATE LOCAL ANALOG LOOPBACK (See Figure 2)**

When the AT&T1 command is entered, the modem goes on hook and configures itself for analog loopback. DSR is turned off (if &S1 is in effect), the analog loopback state is entered, and the test timer is set to the value in S18. A connect result code is sent to the DTE, and the test timer then begins its count down. The test terminates when the test timer expires. If S18 equals 0, then the test must be terminated by a &T0, H0, or Z command. While any command may be entered while the modem is in this test state, the modem response is not specified except for H0, &T0 and Z, any of which will terminate the test. Upon termination of the test, the modem enters the command state.

<b>RESULT CODE</b>	<b>DESCRIPTION</b>
CONNECT	When local analog loopback state is entered.
ERROR	If any other &Tn test is active (except&T0) or if in the on-line command state.
OK	After test is stopped by test timer, the H0 command, or the &T0 command.

## **&T2 NO FUNCTION**

## **&T3 PERFORM LOCAL DIGITAL LOOPBACK (See Figure 3)**

The modem must be in the command state with connection established when this command is issued, otherwise an ERROR result code occurs.

The AT&T3 command establishes a loopback of received data, after demodulation, and sends it back to the distant end. The modem is configured for local digital loopback, DSR is turned off (if &S1 is in effect), the test timer is started with the value in S18, and an OK result code is sent to the DTE. If S18 contains a 0, the test must be terminated by a &T0, H0, or Z command. The latter two result in the modem going on hook. If S18 does not contain 0, the test is terminated after the number of seconds stored in S18.

<b>RESULT CODE</b>	<b>DESCRIPTION</b>
OK	After 2 second delay
ERROR	If any other self test is active (&T1, &T6, &T7 or &T8) or if in idle state. When test is terminated.

## **&T4 GRANT REMOTE DIGITAL LOOPBACK (RDL) REQUESTS**

When in the on-line state, the modem will honor a remote digital loopback request from a distant modem if it occurs. This will result in an ERROR if the command is given while any V.54 test is active (&T1, &T3, &T6, &T7 or &T8).

NOTE: There are data patterns that may cause Remote Digital Loopback conditions. Care should be given to the type of data being received so that no RDL modes will be initiated.

## **&T5 DENY RDL REQUESTS**

The modem will not respond to a remote digital loopback request from a distant modem. This will result in an error if the command is given while any V.54 test is active (&T1, &T3, &T6, &T7 or &T8).

## **&T6 INITIATE REMOTE DIGITAL LOOPBACK (See Figure 4)**

The command is valid only if the modem is in the command state with a connection established.

Configure the modem under test with an AT&T4 command so that it will honor a remote digital loopback request.

Enter AT&T6 at the local modem and it will send a remote digital loopback request to the remote modem. After the RDL acknowledgement signal is received from the remote modem, DSR is turned off (if &S1 is in effect), the on-line state is entered, a CONNECT result code is sent to the DTE, and the test timer is set to the value in S18.

If the local modem does not receive the RDL acknowledgment signal from the remote end in three seconds, it sends an ERROR result code to the DTE and returns to the command state. The local modem sends the signal to release the remote digital loopback when the test is terminated.

The test may be terminated by the H0, Z, or &T0 command. The test will also terminate when the test timer expires (sending the modem to the command state) or carrier is lost (causing a NO CARRIER result code and the modem to go on hook in the command state).

<b>RESULT CODE</b>	<b>DESCRIPTION</b>
CONNECT	When on-line state is entered.
ERROR	If any V.54 test is active (&T1, &T3, &T6-&T8).
ERROR	If not in on-line command state.
ERROR	If the RDL signal is not acknowledged.

## **&T7 INITIATE RDL WITH LOCAL SELF TEST (See Figure 5)**

This is a system test, end to end.

The command is valid only if the modems are in the command state with a connection established.

Configure the remote modem with an AT&T4 command so that it will honor a remote digital loopback request.

Enter AT&T7 at the local modem and it will send a digital loopback request to the remote modem. After the RDL acknowledgment signal is received from the remote modem, DSR is turned off (if &S1 is in effect), the on-line state is entered, an OK result code is sent to the DTE, and the test timer is set to the value in S18. While the test is active, the local modem sends a test message to the remote modem and counts the errors in the received (looped back) signal. The modems stay in the command state during the test. When the test is terminated (except by a loss of carrier), the local modem sends the release signal to the remote modem, as in &T6, and reports the three-digit error count to the DTE.

The information text is followed by an OK result code. The test is terminated by loss of carrier, or an H0, &T0, or Z command, and by the S18 timer running out.

<b>RESULT CODES</b>	<b>DESCRIPTION</b>
OK	When command executed is started.
OK	After error count is sent to DTE (&T1,&T3, &T6, &T7 or &T8).
ERROR	If not in on-line command state.
ERROR	If the RDL signal is not acknowledged.

### **&T8 LOCAL LOOPBACK WITH SELF TEST (See Figure 6)**

The modem should be on hook. Enter AT&T8 to configure the modem for analog loopback and self test. The test timer is started at the time indicated by S18, DSR is turned off (if &S1 is in effect). A self test condition is entered, and an OK result code is sent to the DTE. During the test the modem sends a test message and counts errors in the looped back signal. The test is terminated when the timer times out (S18) or the &T0, H0, or Z command is issued. When the test is terminated, the three digit error count is sent to the DTE. An OK result code follows the error count.

<b>RESULT CODE</b>	<b>DESCRIPTION</b>
OK	If a test state is entered.
OK	After error count is sent to DTE
ERROR	If any other V.54 test is active (&T1, &T3, &T6, &T7), or if on-line.

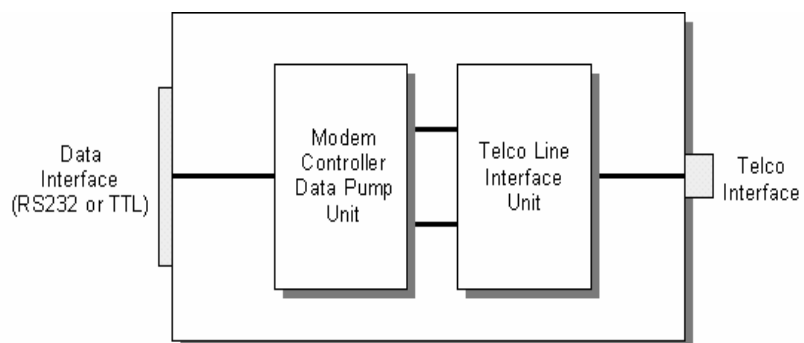

Figure 1 TYPICAL MODEM CONFIGURATION

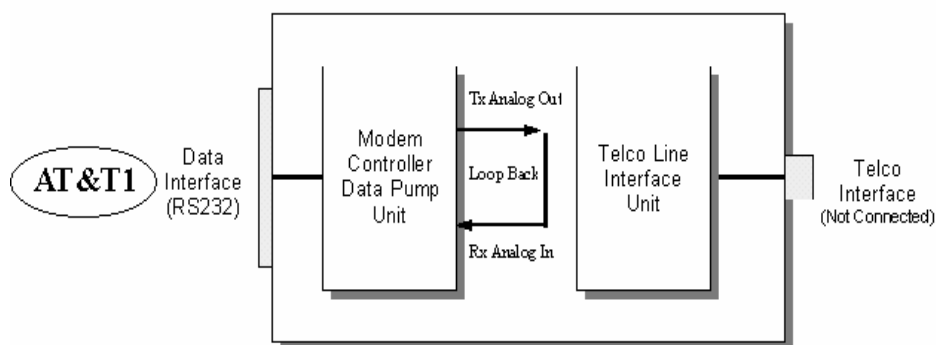

Figure 2 INITIATE LOCAL ANALOG LOOPBACK

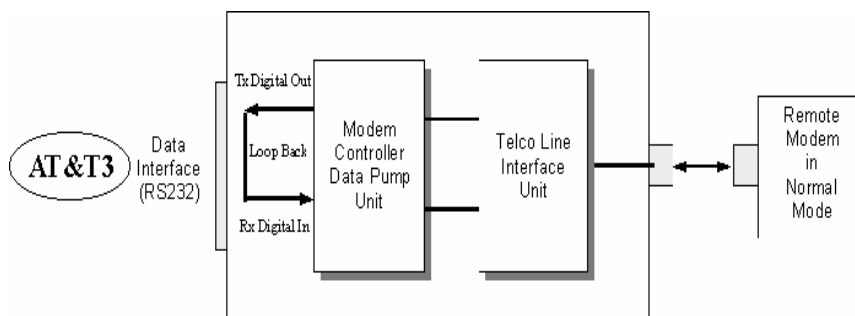

Figure 3 PERFORM LOCAL DIGITAL LOOPBACK

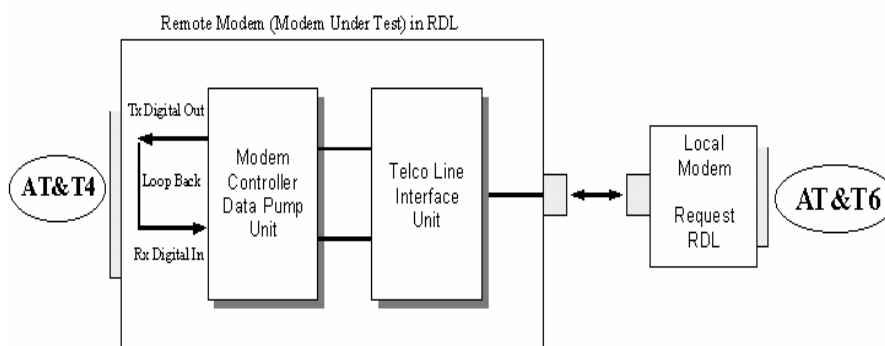

Figure 4 INITIATE REMOTE DIGITAL LOOPBACK

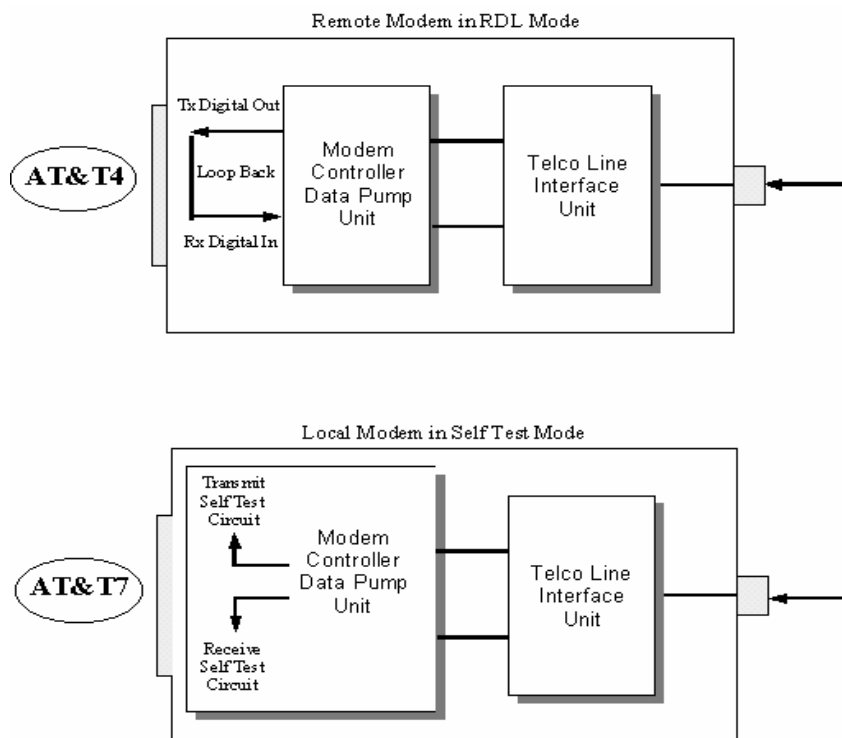

Figure 5 REMOTE DIGITAL LOOPBACK WITH LOCAL SELF TEST

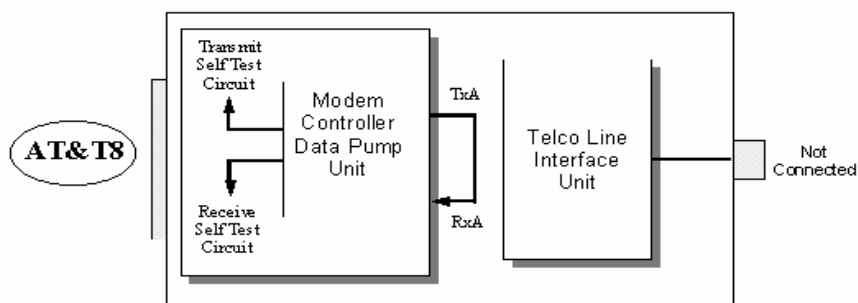

Figure 6 LOCAL ANALOG LOOPBACK WITH SELF TEST

## ADDITIONAL TEST / DIAGNOSTICS COMMANDS

### **%L RECEIVED SIGNAL LEVEL**

Returns a value (-dBm) which indicates the received signal level at modem DATA PUMP interface. This value is determined by the loss/gain of modem Telco Interface circuit  $\pm$ dB at the Tip/Ring input to the modem. Typical value should be -25dBm to -35dBm for most Telco connections.

### **%Q RECEIVED LINE SIGNAL QUALITY**

Reports the line signal quality at the modem DATA PUMP interface. This signal is also dependent on the DAA circuit (Telco Interface). Returns the higher order byte of the EQM (Eye Quality Monitor is the filter squared magnitude of the error vector). Typical value should be below 10. The lower the number, the better the performance from the modem.

ERROR response if NO connection to remote modem.

In &T1, modem %Q will be 0.

### **S86 CONNECTION FAILURE CAUSE**

S86 can help determine the cause of a connection failure. When the modem issues a NO CARRIER result code, a value is written to this register. To read this register, following the connection failure, issue `ATS86? <CR>`. The modem will report one of the following values:

- 0 Normal hang up; no error occurred.
- 4 Physical carrier loss. (Loss of Carrier)
- 5 Feature negotiation failed to detect presence of another V.42 error-control modem at other end.
- 6 Other error-control modem did not respond to feature negotiation message sent by this modem.
- 7 Other modem is synchronous-only; this modem is asynchronous-only.
- 8 Modems could not find a common framing technique.
- 9 Modems could not find a protocol in common.
- 10 Feature negotiation message sent by other modem incorrect.
- 11 Synchronous information (data of flags) not received from other modem.
- 12 Normal disconnect initiated by other modem.

- 13 Other modem did not respond after many transmissions of the same message. Modem made 10 attempts then hung up.
- 14 Protocol violation occurred.
- 15 Compression failure.

Note: Multiple occurrences may contribute to a NO CARRIER message; S86 records the first event that occurred.

## NOTES

## Raymar Information Technology, Inc. Limited Warranty

### One Year Limited Hardware Warranty

Raymar Information Technology, Inc., dba Raymar-Telenetics, warrants their products against defects in hardware, material and workmanship under normal use for one (1) year from the date of purchase. Raymar will, at no charge, either repair the product (with new or reconditioned parts), or replace it (with a new or reconditioned product). Repaired replacement products are warranted for either 90 days or the remainder of the original warranty period, whichever is longer. This warranty extends to the original end-user only.

### What This Warranty Does Not Cover

This warranty does not cover: (a) software; (b) installation or service of the product; (c) conditions resulting from consumer damage such as improper maintenance or misuse, abuse, accident or alteration; (d) all plastic surfaces (including display screens) and all other exposed parts that are scratched or damaged due to normal use; (e) operation of our products with equipment not supplied by Raymar (f) products which have had the serial number removed or made illegible; or (g) products rented to others. This warranty applies only to hardware products manufactured by or for Raymar Information Technology, Inc. and identified by the Raymar-Telenetics trademark, trade name or product identification logo affixed to them. Refer to the Service and Support section of the User's Guide for service after the warranty expires. No warranty is made as to coverage availability or grade of service provided by the carrier.

### General Provisions

This warranty sets forth Raymar's entire hardware responsibilities regarding this product. Repair, replacement or refund of the purchase price is at Raymar's discretion. THIS WARRANTY IS GIVEN IN LIEU OF ALL OTHER EXPRESS WARRANTIES, IMPLIED WARRANTIES, INCLUDING WITHOUT LIMITATION IMPLIED WARRANTIES OF MERCHANTABILITY AND FITNESS FOR A PARTICULAR PURPOSE, AND ARE LIMITED TO THE DURATION OF THIS LIMITED WARRANTY. IN NO EVENT SHALL RAYMAR BE LIABLE FOR DAMAGES IN EXCESS OF THE PURCHASE PRICE OF THE PRODUCT, FOR ANY LOSS OF USE, LOSS OF TIME, INCONVENIENCE, COMMERCIAL LOSS, LOST PROFITS OR SAVINGS, OR OTHER INCIDENTAL, SPECIAL OR CONSEQUENTIAL DAMAGES ARISING OUT OF THE USE OR INABILITY TO USE THIS RAYMAR PRODUCT, TO THE FULL EXTENT SUCH MAY BE DISCLAIMED BY LAW. WITHOUT LIMITING THE FOREGOING, RAYMAR SHALL HAVE NO LIABILITY FOR ANY DATA STORED IN OR USED WITH THE PRODUCT, INCLUDING THE RECOVERY COSTS OF SUCH DATA OR PROGRAMS.

### State Law Rights

SOME STATES DO NOT ALLOW THE EXCLUSION OR LIMITATION OF INCIDENTAL OR CONSEQUENTIAL DAMAGES OR LIMITATIONS ON HOW LONG AN IMPLIED WARRANTY LASTS. THE ABOVE LIMITATIONS OR EXCLUSIONS MAY NOT APPLY TO YOU. This warranty gives you specific legal rights, and you may also have other rights which vary from State to State.

### Provincial Law Rights

SOME PROVINCIAL LAWS DO NOT ALLOW THE EXCLUSION OR LIMITATION OF IMPLIED WARRANTIES, THE EXCLUSION OR LIMITATION OF WARRANTY COVERAGE IN CERTAIN SITUATIONS. SOME OF THE ABOVE LIMITATIONS OR EXCLUSIONS CONTAINED IN THIS LIMITED WARRANTY MAY NOT APPLY TO YOU. This warranty gives you specific rights, and you may have other rights which vary from province to province.

### How To Use Raymar's Limited Warranty Service

To take advantage of this warranty, you must do the following:

- If you are having trouble with your product, contact Raymar service using the appropriate number from the Service and Support section of the User's Guide. If it is determined that your product requires service, you will be issued a Return Materials Authorization (RMA) form.
- Pack the defective product securely for shipping. Include only the units pre-approved by service on your RMA form.
- This warranty is void if the product is damaged in transit, you must insure your shipment.
- Ship the defective product, proof of date of purchase, and the RMA form to the address specified.
- Display your RMA number prominently on the outside of the shipping box. Customer is responsible for freight in, door to door. Raymar is responsible for return shipping costs.
- To ensure prompt service, please write on the RMA form a brief description of the problem you are experiencing with the product.

Raymar Information Technology, Inc.  
7325 Roseville Road  
Sacramento, CA 95842  
Service Hotline (800) 747-1522

<http://support.telenetics.com> or e-mail to [techsupport@raymarinc.com](mailto:techsupport@raymarinc.com)

## **Raymar Information Technology, Inc. Return Merchandise Authorization (RMA) Procedure**

Before returning any Raymar-Telenetics product, an RMA number must be obtained.

The most convenient way to obtain an RMA number for a product purchased from Raymar-Telenetics is to call **1-800-747-1522 (+1-916-783-1951)**. When doing so, please have the following information ready:

- Company name
- Full billing address, as well as the address for the location where the product should be returned once repaired or replaced
- Telephone & Fax numbers
- Email address
- Product model number and serial number

For each item being returned, please include the product model number, the serial number, a description of the problem being encountered, and the cause of the problem (if known).

Please note that prior to authorizing a return, a product support specialist may call to verify that the product is properly installed or may ask you to perform tests to insure that the product has actually failed.

The product must be properly packed and returned to:

**Raymar-Telenetics  
7325 Roseville Road  
Sacramento, CA 95842**

The RMA number must be legibly displayed on the shipping carton. Raymar-Telenetics will not be responsible for any product returned without an RMA number.

If the product is out of warranty, estimates for repair rates and any applicable shipping costs will be communicated by a customer service representative. Currently, Raymar-Telenetics accepts purchase orders or credit cards as payment methods.

Repairs currently require 5 – 10 business days and are returned via UPS Ground.