



Installation, Operation & Diagnostics

2ND Generation MIU202T

Industrial Grade, Bell 202T Standalone Modem



Raymar Information Technology, Inc.

7325 Roseville Road
Sacramento, CA 95842
800-695-1951
Fax: 916-783-1952

The products and programs described in this User's Guide are licensed products of Raymar-Telenetics. This User's Guide contains proprietary information protected by copyright, and this User's Guide and all accompanying hardware and documentation are copyrighted.

Raymar-Telenetics does not warrant that the hardware will work properly in all environments and applications, and makes no warranty and representation, either implied or expressed, with respect to the quality, performance, merchantability, or fitness for a particular purpose.

Information in this User's Guide is subject to change without notice and does not represent a commitment on the part of Raymar-Telenetics. Raymar-Telenetics assumes no responsibility for any inaccuracies that may be contained in this User's Guide.

Raymar-Telenetics makes no commitment to update or keep current the information in this User's Guide, and reserves the right to make changes to this User's Guide and/or product without notice.

No part of this manual may be reproduced or transmitted in any form or by any means, electronic or mechanical, including photocopying, recording, or information storage and retrieval systems, for any purpose other than the purchaser's personal use, without the express written permission of Raymar-Telenetics.

© Copyright 2011 Raymar Information Technology, Inc.
7325 Roseville Road
Sacramento, California 95842
Tel: 800-695-1951 Direct: +1-916-783-1951
Fax: 916-783-1952
Web site: www.raymarinc.com

TABLE of CONTENTS

1. STANDARDS	Page 1
2. PRODUCT OVERVIEW	Page 1
3. GENERAL PRODUCT SPECIFICATIONS.....	Page 2
4. MODEM SPECIFICATIONS.....	Page 2
5. ANALOG LINE SPECIFICATIONS	Page 4
6. ANALOG MICROWAVE SPECIFICATIONS ..	Page 5
7. POWER CONNECTIONS.....	Page 6
8. SERIAL DATA PORT PIN-OUTS	Page 7
9. DIP SWITCH FUNCTIONS.....	Page 8
10.MODEM CONFIGURARION	Page 10
11.LED INDICATOR	Page 11
12.OUTINE DRAWING & MOUNTING.....	Page 12
13.DIAGNOSTICS	Page 13
14.ADDENDUM	Page 19

1. STANDARDS

Meets FCC Rules Part J, Subpart 15, Class A for radiated emissions.

2. PRODUCT OVERVIEW

The MIU202T is an industrial grade Bell 202T modem for connection to unconditioned and conditioned, voice grade, type 3002 two or four-wire leased lines and metallic lines (eg; pilot wires). It can be powered from a wide range of AC and DC power supplies, it is internally surge protected on both the power and analog lines, and it will operate in temperatures from -40 to +85°C.

Internally, the MIU202T consists of a baseboard and a communication module. The baseboard includes the power supply regulation and surge protection. The communication module is a Raymar-Telenetics Pony Express™ PE202T Modem Module.

The MIU202T is packaged specifically for the harsh environments found in utility substations and industrial facilities. Though functionally similar to commercial modems, the MIU202T includes special features that make it particularly well suited for utility and industrial applications:

Environment: The MIU202T has been designed specifically for use in harsh environments. In addition to an extended temperature range (-40 to +85°C), the MIU202T includes surge, shock, vibration, and safety features superior to those of conventional commercial modems.

Power Supply: The MIU202T can be powered from a broad range of AC and DC power supplies, such as an auxiliary supply (eg; 12 VDC) from another piece of equipment, 125 VDC from a station battery or a standard 120VAC.

Industrial: The MIU is packaged in a rugged, compact, non-metallic (ABS) enclosure. Designed for unmanned locations, the MIUs do not include the array of pushbuttons and LEDs normally associated with consumer-type modems. Configuration is by dip switches. Standard industrial connectors for data, analog and power interfaces allow reliable interconnection to other industrial components.

3. GENERAL PRODUCT SPECIFICATIONS

Dimensions: 5.0 x 4.25 x 1.25 inches
 Weight: 1 lb.

Voltage Supply:
 Standard Model: 40 to 270 VDC
 40 to 270 VAC, 50/60 Hz
 LV Model: 9 to 36 VDC

Current Requirements:

12VDC	24VDC	125VDC	120VAC	220VAC
65mA	27mA	7.5mA	6.5mA	5.5mA

Surge Protection:
 Power Supply: 8kVrms
 Analog Line: 3.75kVAC
 Digital Line: ESD ± 10kV

Operating Temperature: -40 to +85°C

Operating Humidity: 0 to 90% (non-condensing)

Storage Temperature: -55 to 100°C

4. MODEM SPECIFICATIONS

Modulation: Bell202T
 Modulation Type: FSK
 Synch/Async: Asynchronous Only
 Data Rate: 0 – 1200bps
 Transmit Frequency: Mark: 1200Hz
 Space: 2200Hz
 Error Correction: None

Data Compression: None

Data Modulation Connectivity:

Using 16ms Polling Test
 99.999% or better at -37dBm
 99.5% or better at -40dBm
 95% or better at -43dBm

Serial Format and Flow Control:

Asynchronous and RTS/CTS flow control

Analog Interface

Tx Output Level: -0dBm or -10dBm *
 Rx Sensitivity: -43dBm or -33dBm *
 -43dBm for constant carrier
 -40dBm for polling carrier

Line Termination: Dip Switch Selectable *
 Line Impedance: 600 ohms balanced
 2 or 4 Wire Configuration: Dip Switch Selectable *

Other Features

Receiver Equalization: Compromise Equalization
 Self Test Diagnostics: None
 Local Analog Loopback: See Section 13
 Local Digital Loopback: See Section 13
 Remote Analog Loopback: See Section 13
 Remote Digital Loopback: See Section 13
 Anti-Streaming: OFF or 45 Seconds (± 5 sec) *
 RTS/CTS delay: 1ms, 12ms, 35ms or 50ms ($\pm 5\%$) *
 Note: Soft Carrier will effect RTS/CTS delay time
 (see Dip Switch Settings – Section 8)
 Constant Carrier: Switch Selectable ON or OFF

Soft Carrier Turn Off 20ms of 900Hz after RTS is turned OFF

Carrier Turn ON/OFF 8ms ± 0.5ms

* Dip Switch Selectable – See Section 9

5. ANALOG LINE SPECIFICATIONS

The MIU202T contains analog circuitry for connection to the public conditioned or unconditioned, Bell type 3002, 2 or 4-wire, full duplex voice grade leased lines or metallic lines (eg; pilot wires). The MIU202T will also interface to Power Line Carrier or Microwave radio voice channel networks.

The MIU202T has an RJ-11 terminated connector. The following lists the MIU202T analog interfaces.

Analog Line Type:

Conditioned or unconditioned, Bell type 3002, 2 or 4-wire, full duplex voice grade or metallic lines or better.

Analog Line Specifications:

Bandwidth	300 Hz to 3400 Hz (±3dB)
Impedance	600 / 900 ohms, balanced
Frequency Response	400 to 3000Hz (±2dB)
Receiver Input Level	-16dBm max.
Output Level	+7 dBm
Noise Signal Level	-48 dBmO

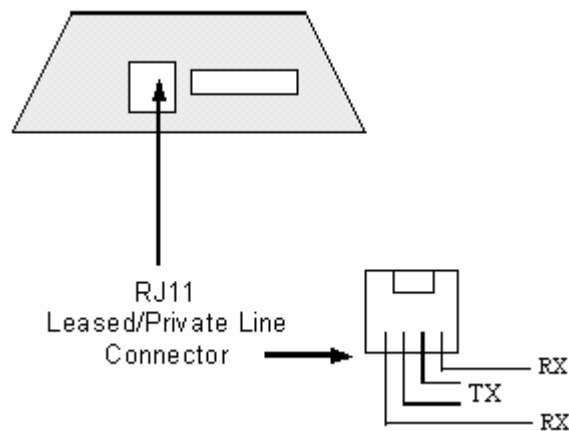

6. ANALOG MICROWAVE INTERFACE

The MIU202T is designed to interface to a Microwave radio voice channel network with the following specifications:

Phase Jitter (10 to 300Hz) 1 degree peak-to-peak, max.

Frequency Response: 300 – 3400Hz -3, +0.7 dB
 400 – 3000Hz -1, +0.7 dB
 600 – 2400Hz ± 0.7 dB

Frequency Stability: With Synchronization 0.1 Hz
 Without Synchronization 0.5 Hz/month

Level Stability (w/o regulation): ± 0.5 dB (6 months)

Harmonic Distortion: 1% max., 0.3% typical
 (1 KHz, 0 dBmO test tone)

Absolute Delay: Option – 001: 1500 µsec, maximum
 Option – 002: 1900 µsec, maximum

Group Delay (option – 001): 600 – 3200 Hz 1200 µsec, maximum
 800 – 2800 Hz 550 µsec, maximum
 1000 – 2600 Hz with 180 µsec, maximum

Linearity: 0.3 dB +3.5 dBmO

Limiting: +7.5 dBmO, max (+6.5 dBmO typical) for +20 dBmO input

Crosstalk (intelligible)(1 KHz test tone at 0 dBmO):
 Inter-channel 65 dBmO maximum, 80 dBmO typical
 Intra-channel 70 dBmO maximum

Crosstalk (unintelligible):
 Adjacent channel 28 dBmO maximum (24 455B weighted noise at 0 dBmO
 dBmO typical).
 Intra-channel 28 dBmO, maximum (18 dBmO, typical)
 (1KHz test tone at 0 dBmO)

Out of Band Signaling: Frequency 3825 Hz
 Level -20 dBmO
 Pulse distortion ±3 dB, level var. 3% max.
 Signaling leak -60 dBmO, maximum

7. POWER CONNECTIONS

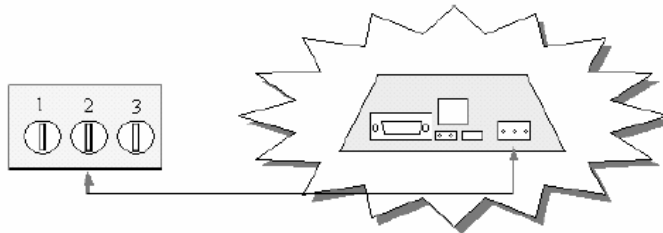

MIU2.4, MIU9.6, MIU9.6L, MIU14.4, MIU14.4L, MIU28.8, MIU202T, MIU9.6FP, MIU9.6FPD

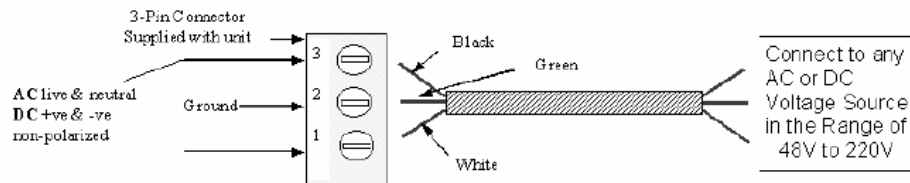

Note: Standard voltage units have black connectors.

MIU Models as above, but with suffix "-LV" (eg; MIU2.4-LV)

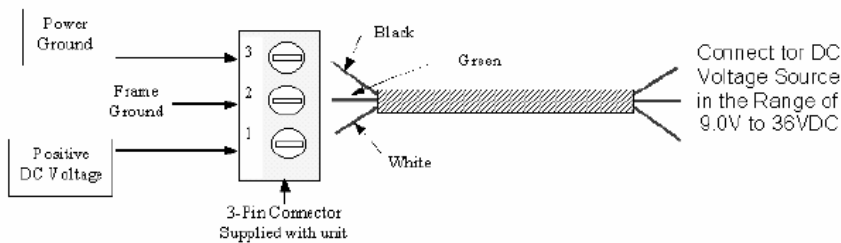

Note: Low voltage units have green connectors.

Important Notes:

1. Wire colors shown are for optional Raymar-Telenetics cable, if ordered.
2. Customer supplies cable must be suitable for site environmental conditions.
3. Surge protection only guaranteed if ground wire >18 AWG
4. Solidly earthed ground connection required to guarantee surge protection.
5. Screw terminals accept 28 to 16 AWG.

8. SERIAL DATA PORT PIN-OUTS

RS232C is the most commonly used serial data interface and defines the Physical, Functional and Electrical boundaries between two or more communicating devices

~ **D-SHAPED SERIAL PORT CONNECTORS** ~
are usually used to interconnect DTEs (computers, controllers, etc.) and DCEs (modems, converters, etc.)

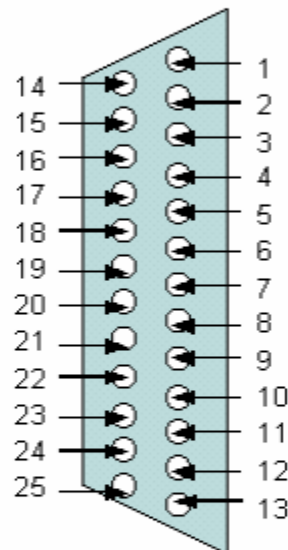
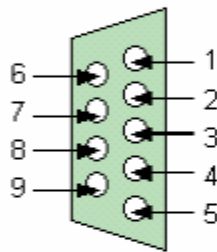

DB9

Pin	Signal	Pin	Source
1	CD - Carrier Detect	8	MODEM
2	RXD - Receive Data	3	MODEM
3	TXD - Transmit Data	2	TERMINAL
4	DTR - Data Term'l Ready	20	TERMINAL
5	Signal Ground	7	N/A
6	DSR - Data Set Ready	6	MODEM
7	RTS - Ready to Send	4	TERMINAL
8	CTS - Clear to Send	5	MODEM
9	RI - Ring Indication (Dial Modems Only)	22	MODEM

DB25

9. DIP SWITCH FUNCTIONS

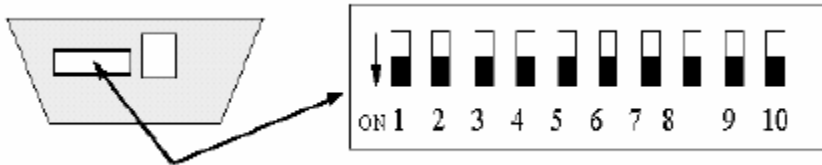

IMPORTANT NOTE: Invert modem to view dip switches as shown above.

Table 1

Switch	Function	ON	OFF
Switch 1	Transmit Analog (TxA) Signal Level	0 dBm	-10 dBm
Switch 2	Anti-Streaming	45 secs	OFF
Switch 3	Received Analog (RxA) Signal Level	-33 dBm	-43 dBm
Switch 4	RTS/CTS Delay	See Table 2	
Switch 5	RTS/CTS Delay	See Table 2	
Switch 6	Switched/Constant Carrier	Constant Carrier	Switched Carrier (Follows RTS State)
Switch 7	2 or 4- Wire Selection	2-Wire	4-Wire
Switch 8	Line Termination	600 ohms	None
Switch 9	Soft Carrier (900 Hz) Turn Off	ON	OFF
Switch 10	Spare		

Table 2: RTS/CTS Delay Time

2 Wire	4 Wire	Switched Carrier	Constant Carrier	Switch 4	Switch 5	Switch 9 Soft Carrier	RTS/CTS Delay Time
NO	YES	YES	YES	ON	ON	OFF	50 ms
YES	NO	YES	NO	ON	ON	ON	50 ms
NO	YES	YES	NO	ON	ON	ON	50 ms
YES	NO	YES	NO	ON	ON	OFF	50 ms
NO	YES	YES	YES	OFF	ON	OFF	35 ms
NO	YES	YES	NO	OFF	ON	ON	35 ms
YES	NO	YES	NO	OFF	ON	ON	35 ms
YES	NO	YES	NO	OFF	ON	OFF	35 ms
NO	YES	YES	YES	ON	OFF	OFF	12 ms
NO	YES	YES	NO	ON	OFF	ON	35 ms
YES	NO	YES	NO	ON	OFF	ON	12 ms
YES	NO	YES	NO	ON	OFF	OFF	12 ms
NO	YES	NO	YES	OFF	OFF	OFF	1 ms
NO	YES	YES	NO	OFF	OFF	OFF	12 ms
NO	YES	YES	NO	OFF	OFF	ON	1 ms
YES	NO	YES	NO	OFF	OFF	OFF	1 ms
YES	NO	YES	NO	OFF	OFF	ON	1 ms

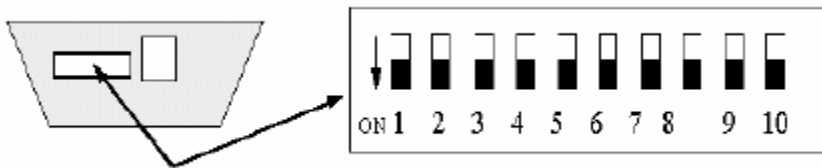

10. MODEM CONFIGURATION

The following table provides the Dip Switch settings required for most modem application configurations:

	Dip Switch Setting								
	1	2	3	4	5	6	7	8	9
4-Wire Point-to-Point	ON		ON			ON		ON	
4-Wire Multi-Point Master	ON		ON			ON		ON	
4-Wire Multi-Point Slave Rx Term. OFF	ON	ON	ON	ON					ON
4-Wire Multi-Point Slave Rx Term. ON	ON	ON	ON	ON				ON	ON
2-Wire Point-to-Point	ON	ON	ON	ON			ON	ON	ON
2-Wire Multi-Point Master Line Term. ON	ON	ON	ON		ON		ON	ON	ON
2-Wire Multi-Point Slave Line Term. ON	ON	ON	ON		ON		ON	ON	ON
2-Wire Multi-Point Slave Line Term. OFF	ON	ON	ON		ON		ON		ON

For clarity, a blank space = OFF

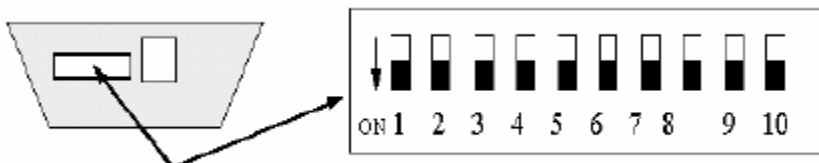

11. LED INDICATOR

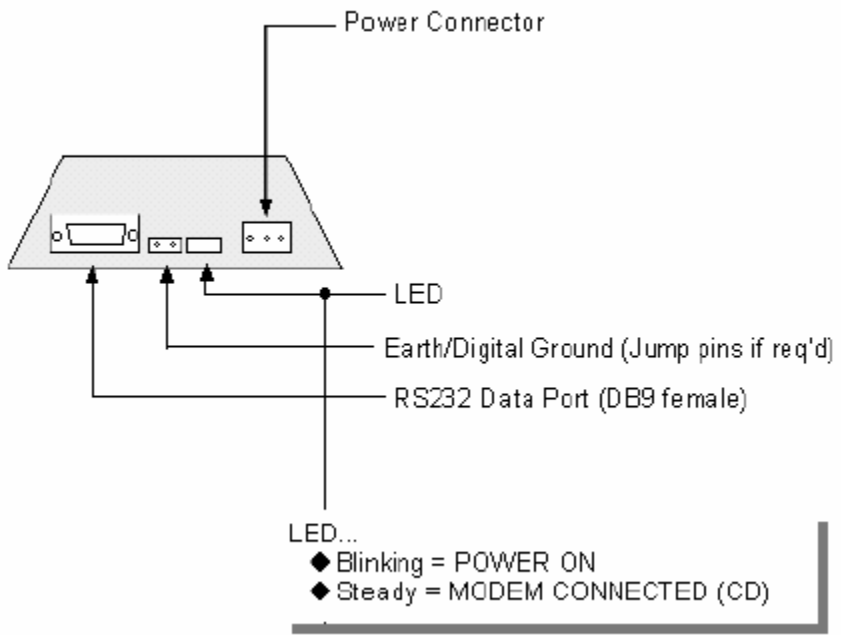

12. OUTLINE DRAWING & MOUNTING

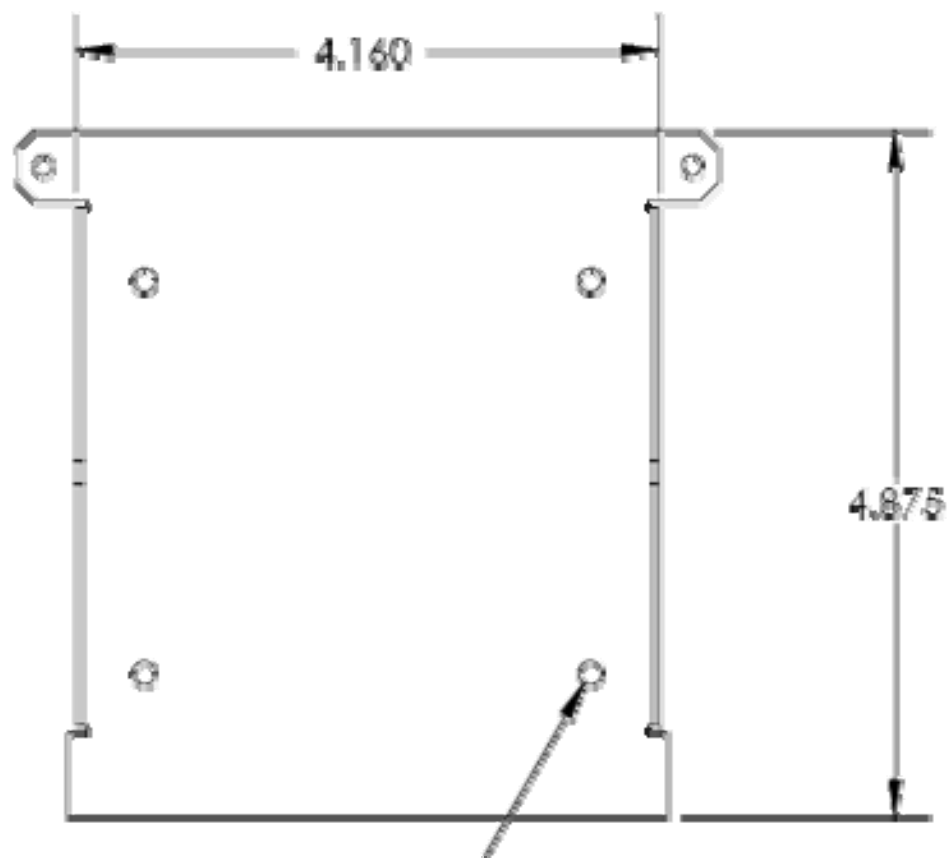

Mounting Options:

Part Number	Description
MIU/DIN	Optional DIN Mounting Clip

13. DIAGNOSTICS

The following pages provide hardware techniques for diagnosing communication problems and thereby isolating the problem at the local modem, the remote modem or the interconnecting line.

(a) LOCAL ANALOG LOOPBACK (Figure 2)

Requires a loop back cable with a built-in circuit for line loss to simulate a typical leased line condition. (See Figure 3)

Connect the loop back cable to the RJ11 connector on the modem under test.

Set Dip Switches as follows:

Switch 7 = OFF	4-Wire
Switch 9 = ON	Soft Carrier Turn Off Enabled
Switch 1 = ON	Transmit (TxA) Signal Level = 0 dBm
Switch 3 = ON	Receive (RxA) Signal Level = -33 dBm
Switch 6 = OFF	Switched Carrier
Switch 4 & 5 = ON	RTS/CTS Delay = 50 ms

Test 1: RTS/CTS Analog Control

Set RTS “ON” and check that CD (Carrier Detect) turns “ON”.

Turn RTS “OFF” and ensure that CD turns “OFF”

With RTS “ON”, run a test message at TxD and verify that the same message is received at RxD with no data errors.

Test 2: Transmit Signal Power & Receive Levels

Set Dip Switch 1 OFF (TxA = -10 dBm)

CD will be OFF

Change Dip Switch 1 to ON (TxA = 0 dBm)

CD should now be ON

Test 3: Received Signal Level

Set Dip Switch 1 OFF (Tx_A = -10 dBm) and Dip Switch 3 OFF (Rx_A = -43 dBm)

CD will be ON

Run a test message at Tx_D and verify that the same message is received at Rx_D with no data errors.

Test 4:

Repeat Test 3 for various RTS/CTS delay times and with soft carrier ON and OFF.

(b) LOCAL DIGITAL LOOPBACK – 4/Wire Network (Figure 4)

On the modem under test, connect Tx_D to Rx_D

Switch 1 = ON (Tx_A = 0 dBm)
Switch 3 = ON (Rx_A = -33 dBm)
Switch 4 = OFF (RTS/CTS = 35 ms)
Switch 5 = ON (RTS/CTS = 35 ms)
Switch 6 = ON (Constant Carrier mode)
Switch 7 = OFF (4-Wire)
Switch 8 = ON (Line Termination = 600 ohms)
Switch 9 = ON (Soft Carrier = ON)

Transmit a test message from a remote modem and confirm that the same message is received back at Rx_D on the remote modem with no data errors.

(c) REMOTE DIGITAL LOOPBACK – 4/Wire Network (Figure 5)

Configure both the local and remote modems as follows:

Switch 1 = ON (Tx_A = 0dBm)
Switch 3 = ON (Rx_A = -33dBm)
Switch 4 = OFF (RTS/CTS = 35 ms)
Switch 5 = ON (RTS/CTS = 35 ms)
Switch 6 = ON (Constant Carrier mode)
Switch 7 = OFF (4-wire)
Switch 8 = ON (Line Termination = 600 ohms)
Switch 9 = ON (Soft Carrier Turn Off = ON)

Connect TxD to RxD at the remote modem.

Transmit a test message from the local modem and confirm that the same message is received back at RxD on the local modem with no data errors.

(d) LINE DIAGNOSTICS

(i) Typical modem configurations for **4-wire Point-to-Point** system:

Switch 1 = ON (TxA = 0dBm)
Switch 3 = ON (RxA = -33dBm)
Switch 4 = OFF (RTS/CTS = 1 ms)
Switch 5 = OFF (RTS/CTS = 1 ms)
Switch 6 = ON (Constant Carrier mode)
Switch 7 = OFF (4-Wire)
Switch 8 = ON (Line Termination = 600 ohms)
Switch 9 = OFF (Soft Carrier = OFF)

(ii) Typical modem configuration for **4-wire Multi-Point** system:

Switch 1 = ON (TxA = 0dBm)
Switch 3 = ON (RxA = -33dBm)
Switch 4 = OFF (RTS/CTS = 1 ms)
Switch 5 = OFF (RTS/CTS = 1 ms)
Switch 6 = ON (Constant Carrier mode)
Switch 7 = OFF (4-Wire)
Switch 8 = ON (Line Termination = 600 ohms)
Switch 9 = OFF (Soft Carrier = OFF)

Adjustments:

In a network with high line loss (greater than 16dB) change Switch 3 (RxA) to OFF (-43dBm).

If there are conditions that can cause cross-talk (TxA leaking into RxA path) set Switch 1 (TxA) to OFF (-10dBm).

Note that noise level should be -50dBm or lower for most FSK operation (signal-to-noise ratio of 15dB or higher).

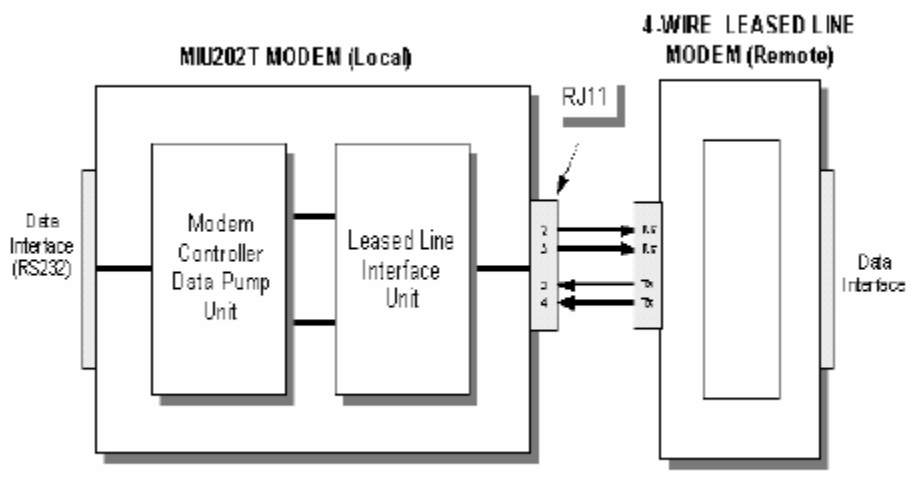

Figure 1 TYPICAL 4-WIRE LEASED LINE MODEM CONFIGURATION

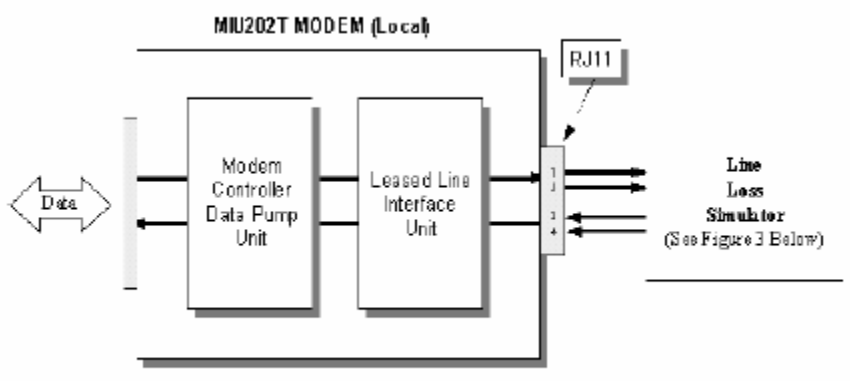

Figure 2 LOCAL ANALOG LOOPBACK

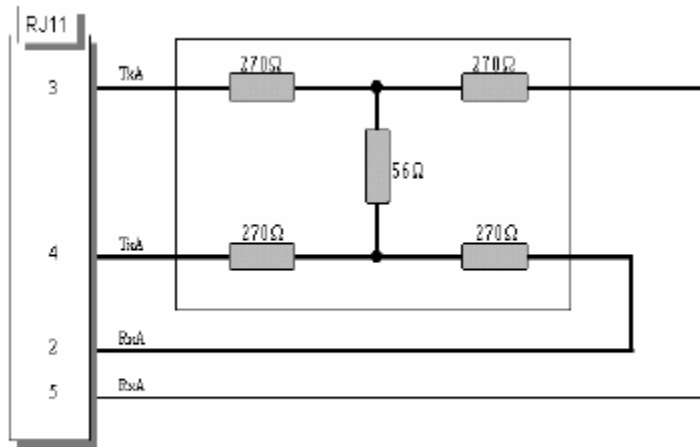

Figure 3 LINE LOSS SIMULATOR (Approx. .26dB)

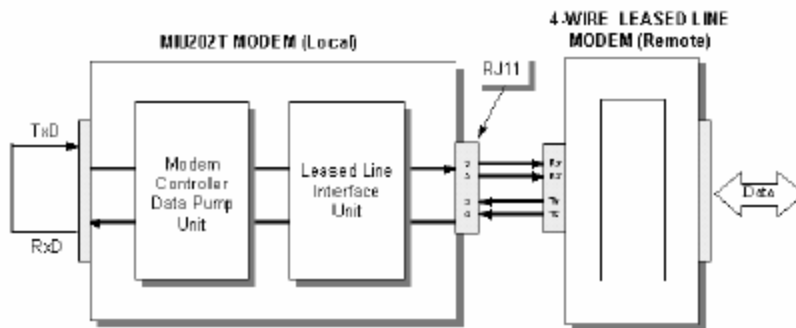

Figure 4 LOCAL DIGITAL LOOPBACK

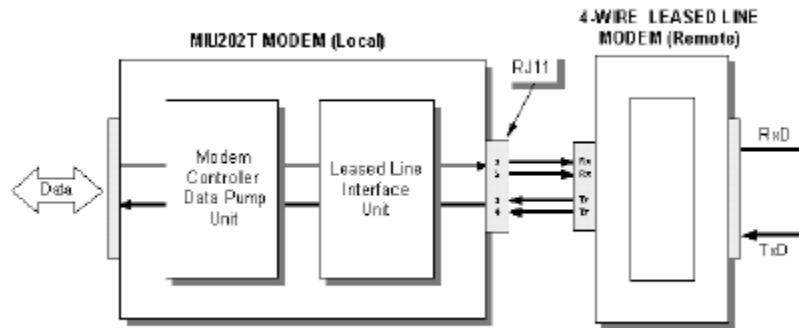

Figure 5 REMOTE DIGITAL LOOPBACK

Addendum

202T Built on 1224 Printed Circuit Board

Test Functions:

A momentary push button switch and two yellow LEDs are provided to perform test functions. When both LEDs are OFF, the modem is in normal mode. Power ON reset insures the modem starts in normal mode.

- 1) Pressing the switch once causes the DL LED to turn ON and the modem is in DIGITAL loopback.
- 2) Pressing the switch a second time illuminates both LEDs, and the modem provides a SPACE frequency carrier.
- 3) Pressing the switch a third time turns on the AL LED, and the modem is in Analog Loopback.
- 4) Pressing the switch one more time returns the modem to normal mode.

Raymar Information Technology, Inc. Limited Warranty

One Year Limited Hardware Warranty

Raymar Information Technology, Inc., dba Raymar-Telenetics, warrants their products against defects in hardware, material and workmanship under normal use for one (1) year from the date of purchase. Raymar will, at no charge, either repair the product (with new or reconditioned parts), or replace it (with a new or reconditioned product). Repaired replacement products are warranted for either 90 days or the remainder of the original warranty period, whichever is longer. This warranty extends to the original end-user only.

What This Warranty Does Not Cover

This warranty does not cover: (a) software; (b) installation or service of the product; (c) conditions resulting from consumer damage such as improper maintenance or misuse, abuse, accident or alteration; (d) all plastic surfaces (including display screens) and all other exposed parts that are scratched or damaged due to normal use; (e) operation of our products with equipment not supplied by Raymar (f) products which have had the serial number removed or made illegible; or (g) products rented to others. This warranty applies only to hardware products manufactured by or for Raymar Information Technology, Inc. and identified by the Raymar-Telenetics trademark, trade name or product identification logo affixed to them. Refer to the Service and Support section of the User's Guide for service after the warranty expires. No warranty is made as to coverage availability or grade of service provided by the carrier.

General Provisions

This warranty sets forth Raymar's entire hardware responsibilities regarding this product. Repair, replacement or refund of the purchase price is at Raymar's discretion. THIS WARRANTY IS GIVEN IN LIEU OF ALL OTHER EXPRESS WARRANTIES, IMPLIED WARRANTIES, INCLUDING WITHOUT LIMITATION IMPLIED WARRANTIES OF MERCHANTABILITY AND FITNESS FOR A PARTICULAR PURPOSE, AND ARE LIMITED TO THE DURATION OF THIS LIMITED WARRANTY. IN NO EVENT SHALL RAYMAR BE LIABLE FOR DAMAGES IN EXCESS OF THE PURCHASE PRICE OF THE PRODUCT, FOR ANY LOSS OF USE, LOSS OF TIME, INCONVENIENCE, COMMERCIAL LOSS, LOST PROFITS OR SAVINGS, OR OTHER INCIDENTAL, SPECIAL OR CONSEQUENTIAL DAMAGES ARISING OUT OF THE USE OR INABILITY TO USE THIS RAYMAR PRODUCT, TO THE FULL EXTENT SUCH MAY BE DISCLAIMED BY LAW. WITHOUT LIMITING THE FOREGOING, RAYMAR SHALL HAVE NO LIABILITY FOR ANY DATA STORED IN OR USED WITH THE PRODUCT, INCLUDING THE RECOVERY COSTS OF SUCH DATA OR PROGRAMS.

State Law Rights

SOME STATES DO NOT ALLOW THE EXCLUSION OR LIMITATION OF INCIDENTAL OR CONSEQUENTIAL DAMAGES OR LIMITATIONS ON HOW LONG AN IMPLIED WARRANTY LASTS. THE ABOVE LIMITATIONS OR EXCLUSIONS MAY NOT APPLY TO YOU. This warranty gives you specific legal rights, and you may also have other rights which vary from State to State.

Provincial Law Rights

SOME PROVINCIAL LAWS DO NOT ALLOW THE EXCLUSION OR LIMITATION OF IMPLIED WARRANTIES, THE EXCLUSION OR LIMITATION OF WARRANTY COVERAGE IN CERTAIN SITUATIONS. SOME OF THE ABOVE LIMITATIONS OR EXCLUSIONS CONTAINED IN THIS LIMITED WARRANTY MAY NOT APPLY TO YOU. This warranty gives you specific rights, and you may have other rights which vary from province to province.

How To Use Raymar's Limited Warranty Service

To take advantage of this warranty, you must do the following:

- If you are having trouble with your product, contact Raymar service using the appropriate number from the Service and Support section of the User's Guide. If it is determined that your product requires service, you will be issued a Return Materials Authorization (RMA) form.
- Pack the defective product securely for shipping. Include only the units pre-approved by service on your RMA form.
- This warranty is void if the product is damaged in transit, you must insure your shipment.
- Ship the defective product, proof of date of purchase, and the RMA form to the address specified.
- Display your RMA number prominently on the outside of the shipping box. Customer is responsible for freight in, door to door. Raymar is responsible for return shipping costs.
- To ensure prompt service, please write on the RMA form a brief description of the problem you are experiencing with the product.

Raymar Information Technology, Inc.

7325 Roseville Road

Sacramento, CA 95842

Service Hotline (800) 747-1522

<http://support.telenetics.com> or e-mail to techsupport@raymarinc.com

Raymar Information Technology, Inc. Return Merchandise Authorization (RMA) Procedure

Before returning any Raymar-Telenetics product, an RMA number must be obtained.

The most convenient way to obtain an RMA number for a product purchased from Raymar-Telenetics is to call **1-800-747-1522 (+1-916-783-1951)**. When doing so, please have the following information ready:

- Company name
- Full billing address, as well as the address for the location where the product should be returned once repaired or replaced
- Telephone & Fax numbers
- Email address
- Product model number and serial number

For each item being returned, please include the product model number, the serial number, a description of the problem being encountered, and the cause of the problem (if known).

Please note that prior to authorizing a return, a product support specialist may call to verify that the product is properly installed or may ask you to perform tests to insure that the product has actually failed.

The product must be properly packed and returned to:

**Raymar-Telenetics
7325 Roseville Road
Sacramento, CA 95842**

The RMA number must be legibly displayed on the shipping carton. Raymar-Telenetics will not be responsible for any product returned without an RMA number.

If the product is out of warranty, estimates for repair rates and any applicable shipping costs will be communicated by a customer service representative. Currently, Raymar-Telenetics accepts purchase orders or credit cards as payment methods.

Repairs currently require 5 – 10 business days and are returned via UPS Ground.

All repaired products carry a 90-day warranty, beginning from the date shipped from Raymar's facility.