



CSU-DSU/6440
Digital Termination Unit
User's Guide



Raymar Information Technology, Inc.

7325 Roseville Road
Sacramento, CA 95842
800-695-1951
Fax: 916-783-1952

The products and programs described in this User's Guide are licensed products of Raymar-Telenetics. This User's Guide contains proprietary information protected by copyright, and this User's Guide and all accompanying hardware and documentation are copyrighted.

Raymar-Telenetics does not warrant that the hardware will work properly in all environments and applications, and makes no warranty and representation, either implied or expressed, with respect to the quality, performance, merchantability, or fitness for a particular purpose.

Information in this User's Guide is subject to change without notice and does not represent a commitment on the part of Raymar-Telenetics. Raymar-Telenetics assumes no responsibility for any inaccuracies that may be contained in this User's Guide.

Raymar-Telenetics makes no commitment to update or keep current the information in this User's Guide, and reserves the right to make changes to this User's Guide and/or product without notice.

No part of this manual may be reproduced or transmitted in any form or by any means, electronic or mechanical, including photocopying, recording, or information storage and retrieval systems, for any purpose other than the purchaser's personal use, without the express written permission of Raymar-Telenetics.

© Copyright 2010 Raymar Information Technology, Inc.
7325 Roseville Road
Sacramento, California 95842
Tel: 800-695-1951 Direct: +1-916-783-1951
Fax: 916-783-1952
Web site: www.raymarinc.com

The United States Government Federal Communications Commission has specified that the following notice be brought to the attention of users of this product:

WARNING

This equipment generates, uses, and can radiate radio frequency energy and if not installed and used in accordance with the instruction manual, may cause interference with radio communications. It has been tested and found to comply with the limits for a Class A computing device pursuant to Subpart J of Part 15 of FCC Rules, which are designed to provide reasonable protection against such interference when operated in a commercial environment. Operation of this equipment in a residential area is likely to cause interference, in which case the user, at their own expense, will be required to take whatever measure may be required to correct the interference. In order to ensure FCC compliance, only properly constructed, terminated, and shielded cabling should be used with this product.

NOTE:

This digital apparatus does not exceed the Class A limits for radio noise emissions from digital apparatus as set forth in the radio interference regulations of the Canadian Department of Communications.

FCC REQUIRED INFORMATION

The following information is required for inclusion in this manual by the FCC:

This equipment complies with Part 68 of the FCC rules. On the bottom of the unit is a label that contains, among other information, the FCC registration number and ringer equivalence number (REN) for this equipment. If requested, this information must be provided to the telephone company.

This equipment uses the following USOC jack: RJ48S.

The REN is used to determine the quantity of devices, which may be connected to the telephone line. Excessive REN's on the telephone line may result in the devices not ringing in response to an incoming call. In most, but not all areas, the sum of the REN's should not exceed five (5.0). To be certain of the number of devices that may be connected to the line, as determined by the total REN's contact the telephone company to determine the maximum REN for the calling area.

If this equipment causes harm to the telephone network, the telephone company will notify you in advance that temporary discontinuance of service may be required. If advance notice isn't practical, the telephone company will notify the customer as soon as possible. Also, you will be advised of your right to file a complaint with the FCC if you believe it is necessary.

The telephone company may make changes in its facilities, equipment, operations, or procedures that could affect the operation of the equipment. If this happens, the telephone company will

provide advance notice in order for you to make the necessary modifications in order to maintain uninterrupted service.

If trouble is experienced with this equipment, please contact Raymar-Telenetics at (800) 695-1951 for repair and (or) warranty information. If the trouble is causing harm to the telephone network, the telephone company may request that you remove the equipment from the network until the problem is resolved.

The following repairs can be done by the customer: none.

This equipment cannot be used on telephone company-provided coin service. Connection to Party Line Service is subject to state tariffs.

TABLE of CONTENTS

1. ABOUT THIS MANUAL.....	Page 1
2. CONVENTIONS USED	Page 1
3. CHAPTER ONE - INTRODUCTION.....	Page 2
4. CHAPTER TWO - INSTALLATION	Page 5
5. CHAPTER THREE - OPERATION.....	Page 13
6. APPENDIX A – CABLE DIAGRAMS.....	Page 18
7. LIMITED WARRANTY	Page 20
8. RMA PROCEDURE.....	Page 21

About This Manual

This manual covers installation and operation of the CSU-DSU/6440 Digital Termination Unit (DTU). Designed for use in a Dataphone Digital Service (or DDS) network, this digital termination unit connects two remote locations together to form a wide area network. All DDS speeds are supported as well as speeds that may only appear in Limited Distance Modem (LDM) applications.

Conventions Used in This Manual

DTU	Refers to a Digital Termination Unit. The DTU is the combination of a Channel Service Unit and a Data Service Unit in a single packaging.
CSU	Refers to a Channel Service Unit.
DSU	Refers to a Data Service Unit.
DDS	Refers to a Dataphone Digital Service as originally created by AT&T. Many of the regional Bell operating companies and their common carriers have their own designation for DDS facilities.
UNIT	Refers to the 6420 DTU.
DTE	Refers to Data Terminal Equipment.
DCE	Refers to Data Communications Equipment. A device that establishes, maintains, and terminates a data communications session and provides encoding or conversion if necessary.
TELCO	Refers generically to any of the common carriers.
MARK	A condition in which the TELCO line is transmitting or receiving an all ones signal.
SPACE	A condition in which the TELCO line is transmitting or receiving an all zeros signal.

Chapter One – Introduction

The 6440 Four Channel CSU-DSU is an advanced Channel Service Unit/Data Service Unit based on the new Digital Signal Processor technology. The 6440 is capable of operating in a point-to-point environment on a Dataphone Digital Service (DDS) as provided by the common carriers and offers two independent channels that simultaneously transfer customer's data.

This manual provides all of the information needed to install, set-up, and operate a system of 6440 digital termination units. The 6440 is a four channel digital termination unit that operates at all common speeds between 2,400bps and 64,000bps. The data termination unit offers a combination of port speeds; the sum of which must be less than the selected line speed. The 6440 supports asynchronous and synchronous operation.

All channels on the 6440 are terminated with RS-232 signaling on DB-25 connectors. Limited Distance Modem operation is also available on the 6440 with one unit configured with a master clock setting. At 56,000bps, depending upon wire gauge, the 6440 can operate error-free at up to ten miles distance.

The unit is also equipped with three push button switches, accessed from the front of the unit, to provide configuration, installation, and diagnostic assistance. An LCD display positioned adjacent to the push button switches provides a visual interface into the menu system of the 6440 as well as the operation of the unit.

A complete menu system is provided for the user to configure, test, and observe operation of the unit. The three push buttons—labeled Select, Advance, and Enter—allow for a simple manipulation of the 6440 through port and line settings, diagnostic testing, and selection of an operational display.

Among the operational displays are LED status simulations as well as both port and line utilization statistics.

Speed matching is provided for all defined line speeds that have DTE port speeds that are less than the line speed for all common DTE speeds. This is subject to the limitation that the two port speeds must sum to less than the line speed value. In addition, synchronous and asynchronous character formats and timings are supported.

Electrical requirements are supplied by an external power transformer that accepts 117VAC and supplies 10VAC to the 6440. The electrical connection is therefore free from any dangerous voltages on the PC board itself. UL and CSA approvals exist for the power transformer separately from the unit.

When in actual operation, simulated LED indicators are provided on the LCD front panel display. From left to right, they are In Svc, Car Det, Req Send, Clr Send, Send Data, and Recv Data. A separate portion of the menu system provides access to diagnostic controls that include Self-Test, Digital Loop, Local Loop, and Remote Loop.

Physical Description

The 6440 is a stand-alone unit that is used in a desk top configuration. The front panel is labeled appropriately so that the controls and indicators may be read from a normal viewing position. The unit is also available in a rack mount configuration - the 6440-R. This unit is identical to the desk top unit.

The case is painted metal and provides adequate electronic shielding from other nearby components. The front panel contains a LCD display and three push button switches. The rear panel contains two DB-25 DTE connectors (labeled Port1 and Port 2), one V.35 DTE connector (labeled V.35 Port 1), a power connection receptacle, and an RJ48S network connection receptacle.

Shipped with the unit is a straight through RJ48S male-male network connection cable, and a 10VAC, one amp power supply. The unit is a DCE device and only requires straight through cables for all DTE equipment. Cable considerations are discussed in **Appendix A**.

Physical Specifications

Regulatory Approvals: FCC Class A approved. UL, CSA approved. FCC Part 68 approved (1U5USA-74399-DE-N)

Connectors: Four female DB-25s for connection to the DTE equipment, one female RJ48S for connection to the telephone network and one female power connector. All pinouts are given in **Appendix A**.

Storage Temperature: 0 to +70 C

Operating Temperature: 0 to +40 C

Power Requirements: 117VAC, 47-63Hz—external transformer

Approximate Weight: two pounds

Operating Humidity: Up to 95% non-condensing

Operating Air Pressure: 10,000 feet (3050 m) maximum altitude

Dimensions: 7.85" (W) x 6.75" (D) x 2.50" (H)

DTE Synchronous Data Rates: 600, 1200, 2400, 4800, 9600, 14400, 19200, 28800, and 38400 bits per second

DTE Asynchronous Data Rates: 300, 600, 1200, 2400, 4800, 9600, 19200, and 38400 bits per second

Line Data Rates: 2400, 4800, 9600, 19200, 38400, 56000, and 64000 bits per second

Character Format Asynchronous: five, six, seven, or eight bits per character – does not include start and stop bits.

Character Format Synchronous: eight bits per character

Receiver Sensitivity: 0 to -45dbm for 56,000 bps operation

Chapter Two – Installation

Unpacking

All CSU/DSU series products are shipped in corrugated cardboard boxes. Suitable packing material is used to insure that the unit, together with its power transformer and network connection cable, are secure during transport. Unpacking consists of opening the carton and removing the equipment. It is recommended that the packing material be retained should it ever be necessary to re-transport the equipment. After unpacking, all equipment should be inspected for damage or deficiencies. Any damage or deficiency should be immediately reported to Raymar-Telenetics' customer service.

Inspection

When the initial inspection has been completed, the equipment should be identified and verified against the accompanying shipping documents. Each item should be checked for the correct model and serial number as indicated on the shipping list. The bottom of the unit chassis bears a label on which the unit's model, serial number, and certifications are printed. Any discrepancies should be immediately reported to Raymar-Telenetics.

If the carton containing the unit is obviously damaged by the shipping carrier, file a claim immediately, then contact Raymar-Telenetics customer service for additional instructions and quick-check procedures for the damaged equipment. This procedure may allow warranty provisions to remain in effect.

Location Determination

It is recommended that a grounded 117VAC, 47-63 Hertz power receptacle be used. The power transformer provides a six-foot, two-conductor cable with the appropriate power connector for the unit. Be sure that the DTE cable is long enough to reach to the rear of the unit. Position the unit within a convenient distance from the DTE equipment and communications network interface that enables any cable to be connected without stretching or binding. At this point, do not connect any cables until the unit has been configured through its LCD display on the front panel.

Primary Channel Connection

At the rear of the unit are four DB-25 RS-232 female connectors. These are for a DTE user connection to the unit. Each connector is configured as a DCE. Any DTE device connecting to a 6440 port should use a straight through cable. Cable lengths should be restricted to less than six feet for RS-232 connections. Shielded cables should be used exclusively. Pinouts for the various cables are shown in **Appendix A**.

RJ48S Network Connection

The communications Network Connection is a four-wire connection using an eight-wire connector—the RJ48S. This connector is so designated by Bell Core as the proper termination for a DDS circuit. Typically, a common carrier will terminate the DDS circuit in a connector containing a female RJ48S receiver. Raymar-Telenetics supplies a straight through six-foot RJ48S cable with male connectors at each end. The network interface connection is made directly between the RJ48S female receiver on the rear of the unit and the female connector provided by the service provider. The female RJ48S connector, as viewed by looking directly at the rear of the unit, contains the pin designation numbers, 1 through 8, beginning with pin 1 at the left and ending with pin 8 at the right. Pins 1 and 2 are the transmit pair. Pins 7 and 8 are the receive pair. Pins 3 through 6 are not used.

1	2	3	4	5	6	7	8
TX Pair		Not Used				RX Pair	

Dataphone Digital Service is tariffed in various geographical areas throughout the United States with slight variations. Inclusive of all geographical areas are speeds ranging from 2,400bps to 64,000bps. The 6440 supports all available speeds as tariffed by the various service providers. DDS is by definition a synchronous service. The 6440 provides both asynchronous and synchronous operation. Asynchronous DTE connections are converted to synchronous connections by the 6440, transmitted as synchronous data over the DDS link, and reconverted to asynchronous at the remote 6440 location.

Local loop lengths will vary depending upon proximity of the end user's location to the local service provider. The unit uses an automatic gain control system to compensate for various local loop lengths. The receiver range is 0 to -45dBm at 56,000bps, which permits operation over long local loops (in excess of 18,000 feet using 26 gauge wire). It should be noted that central office OCUs used by the service provider must also be capable of operation with this same receiver range in order for the unit to operate at this extended local loop distance.

Menu Interface – LCD Display

The menu system is accessed through the LCD display using three push buttons—Select, Advance, and Enter. The LCD display is a single line, 16 character position display.

Select

When depressed, this button places the unit in a non-operational mode at the top of the menu tree. The top of the menu tree is the Configuration option of the unit.

Advance

When depressed, this button displays the next option in a series of options. As an example, when in configuration mode, the Advance button displays the next line speed, port speed, async or sync, etc. When in operational mode, the next real-time operational mode is displayed (e.g. LED simulations and Port utilization statistics).

Enter

This button accepts the option displayed in the LCD window as current, then displays the next option in a series of options. The functionality is similar to the Advance button in that it displays an option, but differs in that the option is actually selected and used or executed (e.g. Enter actually begins execution of a Digital Loop after being displayed by Advance).

Top Level Menu

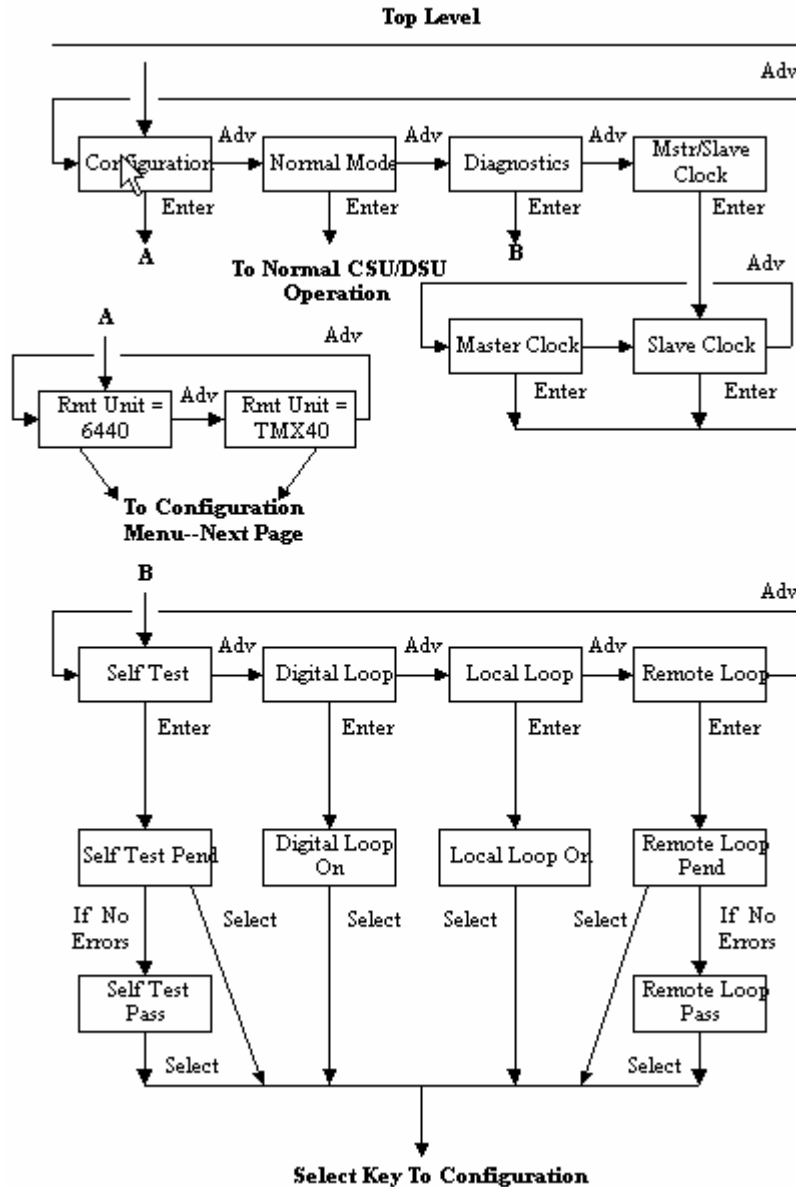

Configuration Level Menu

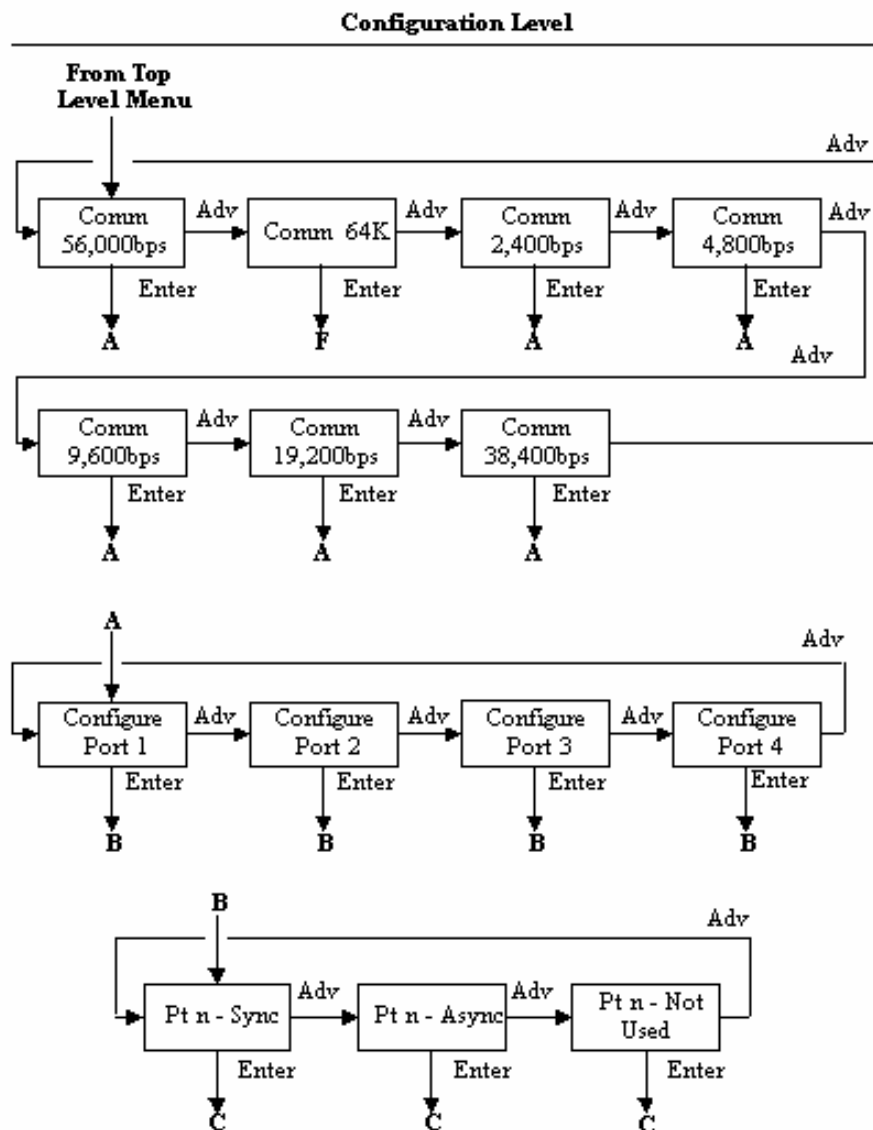

Configuration Level (Continued)

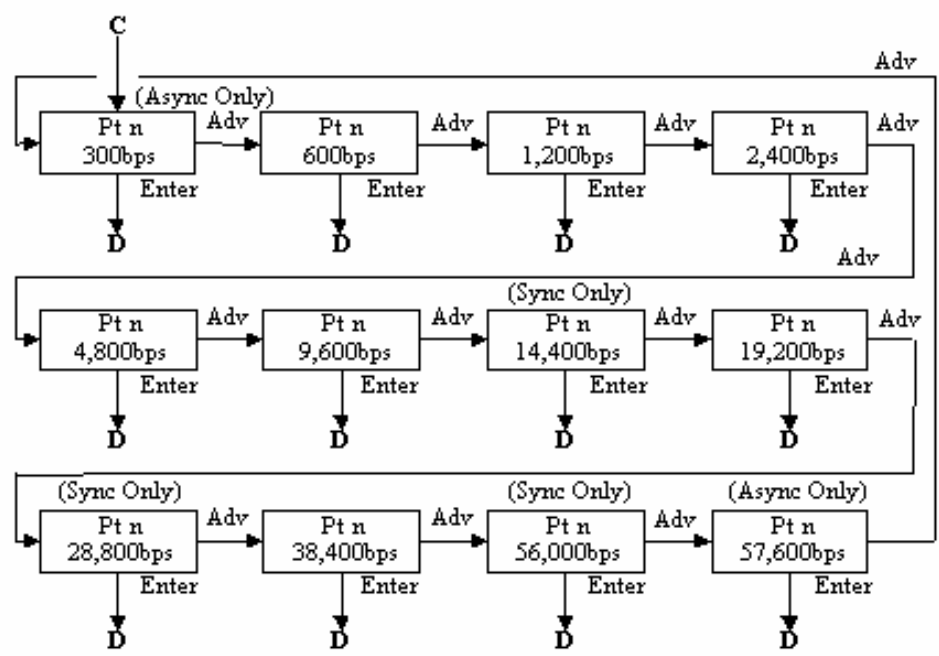

(Note: Sync - G Next)

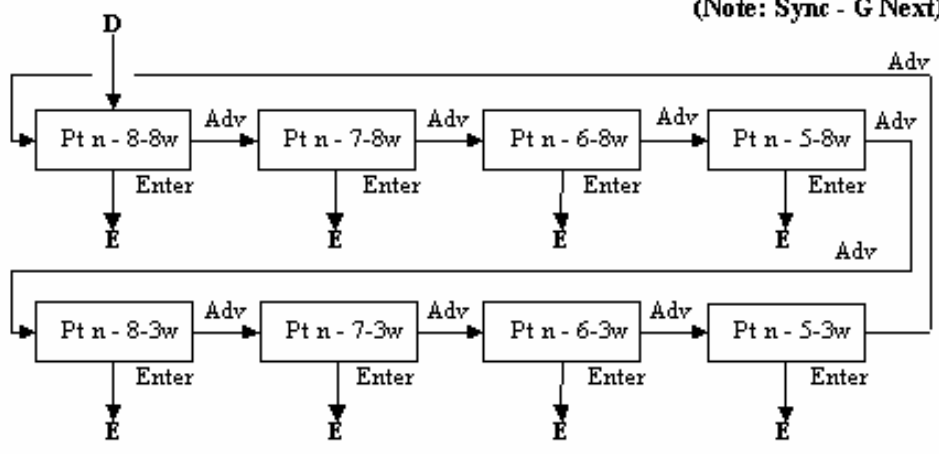

Configuration Level (Continued)

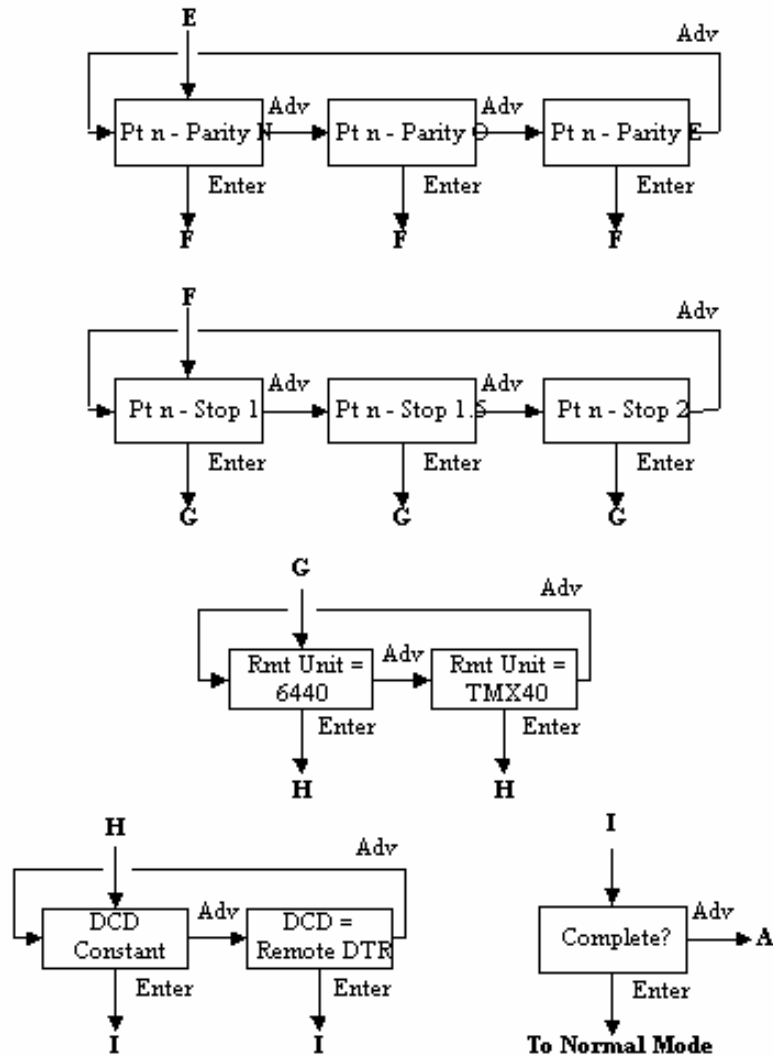

Operational Level

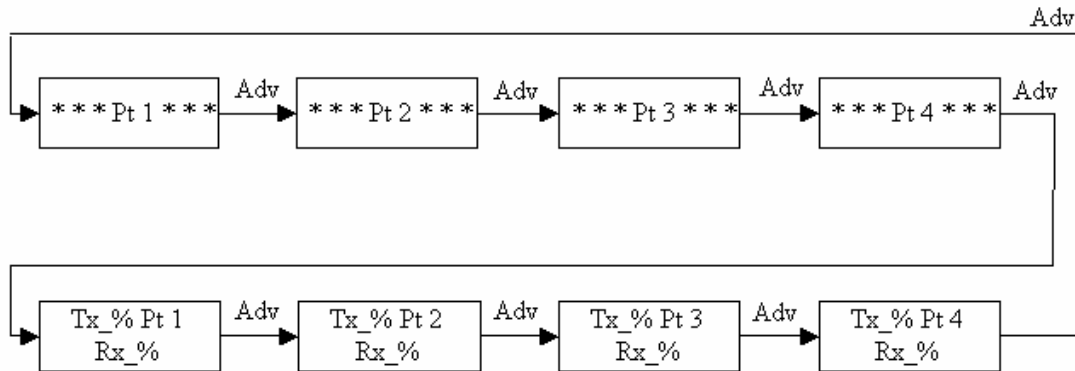

Unsolicited Status Messages

Stand by ...	The units are attempting to synchronize their time division multiplexers
Out of Service	Out of Service pattern being received from Telco central office OCU – No remote unit is connected to the line
No Signal	No signal is being received from the Telco line that is connected
Telco CSU Loop	Telephone company latching Channel Service Unit loop test is in progress
Telco DSU Loop	Telephone company non-latching Data Service Unit loop test is in progress
TDM Overbooked	Current port configuration exceeds the capacity of the specified line speed

Operating the Menu System

Please note the following comments regarding the menu system and its operation:

1. When pressing the **Advance** button, if you go beyond the desired parameter, continue pressing the button until the desired parameter appears again on the LCD display. All advance parameters are circularly arranged in the menu system.
2. If you select the Comm 64 line speed, this is a DDS-only Clear Channel selection. The Master/Slave clock setting is ignored and defaulted to slave clock. Bench testing is not possible without a pair of Office Channel Units (OCUs).
3. The **DCD Constant** and **DCD = Rmt DTR** parameters are not intended to serve as a flow control system. For the selection **DCD = Rmt DTR**, the setting of DCD as a result of DTR at the remote location may be as long as 250 milliseconds.
4. Upon initial start-up, the operational display always defaults to the “Pt 1” display on the LCD. By pressing the **Advance** button, other operational displays may be selected—see the Operational Level menu.
5. The lead status display of the Operational Level menu is a simulation of an LED. The sampling rate is such that single character transmissions rarely show up as an “*.” Only one bit out of every fifty is used to activate the “Send” and “Receive” data asterisk displays.
6. For Clear Channel 64 Kbps telco testing, only the latching Telco CSU Loop test is supported. The non-latching Telco DSU Loop test is not supported.

Chapter Three – Operation

Normal operational mode is achieved once the unit has been configured through its front panel LCD display, power is supplied by the external transformer, the network connection is made with the RJ48S cable, and the DTE devices are attached via the DB25/RS-232 ports. Normal operation is present when the front panel LCD display shows a simulated LED pattern with a solid In Svc “*”. This appears at the left most character position of the LCD display below the label **In Svc**.

Front Panel Operation

The front panel of the unit contains six LEDs that indicate the status of the multiplexer. The right five LEDs are directly connected to the composite link and reflect its status. The LEDs are labeled from left to right as follows:

In/Svc	When on steady, indicates a correct (In Service) pattern from the Telco is being received.
Car/Det	When on, this indicates valid data is present on the DDS receive line pair.
Req/Send	When on, this indicates RTS is present from the DTE or is being provided by the unit itself (RTS constant).
Clr/Send	When on, this indicates that the unit is In Service and has a valid RTS signal from the DTE terminal.
Send/Data	Flashes when transmit data is present (a Space condition turns on LED)
Recv/Data	Flashes when receive data is present (a Space condition turns on LED).

Run-time Operational Displays

The unit has eight operational displays that may be selected during normal operation. When the unit first becomes operational, a lead status simulation as described above is shown on the LCD display for Port 1. The center of the display reads “Pt 1” to indicate that the Port 1 leads are being displayed. A single depression of the Advance button switches the display to Port 2. Additional depressions of the Advance button display port 3 and port 4* LEDs and port utilization statistics for each port. This display shows the word “Pt 1” or “Pt 2” or “Pt 3” or “Pt 4” in the center and gives a real-time updated display of the transmit and receive utilization as functional of total capacity. This is displayed as a percentage.

Self Test

Self Test is entered by depressing the Select button once, the Advance button twice, then the Enter button twice.

Self Test causes the unit to internally connect its transmitter to its receiver. An internal pattern generator then begins outputting a known pattern of data, which is checked for accuracy as it is received back internally. During this process, the LCD displays Self Test Pend. Once the pattern has been received correctly for five to ten seconds (this varies with the speed selected for the unit), the LCD displays the message Self Test Pass. The message condition continues for as long as the unit correctly receives the test pattern. A depression of the Select button ends the Self Test and places the unit at the Configuration menu level. Self Test may be initiated without having any network connection. It is recommended that the first test performed to validate the unit's operation is the Self Test.

Digital Loop

Digital Loop is entered by depressing the Select button once, the Advance button twice, the Enter button once, the Advance button once, then the Enter button once.

Digital Loop performs a bi-directional loopback at the main processor of the unit. All data arriving from the network is reflected back to the network; all data received from the ports is reflected back to the ports. Both reflections are simultaneous and independent. A single depression of the Select button ends the Digital Loop and returns the unit to the Configuration menu level.

Local Loop

Local Loop is entered by depressing the Select button once, the Advance button twice, the Enter button once, the Advance button twice, then the Enter button once.

Local Loop performs a bi-directional loopback at the network interface connection of the unit. All data arriving from the network are reflected back to the network; all data received from the port is reflected back to the port. Both reflections are simultaneous and independent. A single depression of the Select button ends the Local Loop and returns the unit to the Configuration menu level.

Remote Loop

Remote Loop is entered by depressing the Select button once, the Advance button twice, the Enter button once, the Advance button three times, then the enter button once.

This test is extremely useful in initial installations on new DDS circuits. **If the pair of units do not pass the Rmt/Loop test, they will not pass data correctly from the DTE sources.** Raymar-Telenetics Technical Support will always verify with an end user that the units do or do not pass the Remote Loop test before proceeding to other correctional activities. Often times a Remote Loop test initiated from one end will operate in one direction but not the other. Under these circumstances it is easy to identify which pair of DDS wires (Transmit or Receive) is functional and which is not.

This test can be performed only between two ATL 6440 series CSU/DSU units. The initiating unit begins outputting a data pattern on its transmit pair to a remote unit. The remote unit observes the test pattern for five to ten seconds to determine whether or not the pattern is accurate and valid. If so, the remote unit displays the LCD message Remote Loop Pend and begins transmitting the same test pattern back to the originator. The originator observes the incoming data for the presence of the special test pattern of data. Once received for five to ten seconds, the originating unit changes its initial LCD message, Remote Loop Pend, to Remote Loop Pass.

Once this test is in operation, any bit errors detected by the originator or the remote unit will cause the LCD message to revert back to a Remote Loop Pend condition. This will continue as long as bit errors are detected. When the pattern is again received accurately, the Remote Loop Pass message is again displayed.

To terminate the Remote Loop test, a single depression of the Select button returns the unit to the Configuration menu level.

Front Panel Lock

To insure that an operational condition is not accidentally interrupted, the 6440 has the facility to lock and unlock its front panel push buttons. This is accomplished by simultaneously depressing the Advance and Enter buttons while in operational mode and holding them for a period of five seconds. At this point, the LCD display will show a "...Locked..." message. The unlock is accomplished in exactly the same fashion, by depressing the Advance and Enter buttons for five seconds.

Factory Configuration

The ATL CSU-DSU/6440 is shipped with a factory configuration of 56,000bps line, 9.600bps on each port, synchronous, slave clock, and RTS constant. At any time, this configuration may again be selected by simultaneously depressing all three push buttons while applying power to the unit.

TDM Overbooking

While configuring the 6440, it is possible to overbook or allocate to the ports more bits per second capacity than is available on the line. If this happens, the message "TDM Overbooked..." is presented on the front panel LCD. Unlike all other conditions, it is necessary to press **Enter** to release this message and return to the Configuration position of the menu. When a valid port configuration is input, the overbooked message does not appear.

Telco Central Office Loopbacks

The unit is constructed to perform the mandatory telephone company initiated loopbacks—CSU Loop and DSU Loop.

Telco CSU Loopback

The Telco CSU Loopback condition is initiated by the telephone company by performing a sealing current reversal on the DDS circuit. The unit senses this condition and initiates a uni-directional loopback at the network interface. While in this mode of operation any data sent by the telephone company will be reflected back at the network interface. The unit displays the message Telco CSU Loop on the LCD front panel.

Telco DSU Loopback

The Telco DSU Loopback is initiated by the telephone company by performing a specific bipolar code violation on the DDS circuit. The unit senses this condition and initiates a uni-directional loopback at the processor interface. While in this mode of operation, any data sent by the telephone company will be reflected back. The unit displays the message Telco DSU Loop on the LCD front panel.

Five Minute Timer

The unit employs an internal five-minute timer that monitors any user initiated test condition. After five minutes of being in a non-operational state other than the Telco CSU and DSU loopbacks, the unit automatically returns to a normal operating condition. This prevents the unit from accidentally being left in a test condition.

Limited Distance Modem Operation

The 6440 CSU/DSU units operate extremely well as Limited Distance Modems or LDMs. This capability is for line speeds of 56,000bps or less. The connecting copper wire may be provided as private end user cabling or be provided as un-loaded cabling from the local telephone company.

The distance that the unit may traverse depends on the wire gauge used along with the number of splice points that the wire may have, as well as the speed at which the units must operate. The following table is provided as reference information for an end user's decision as to the appropriateness for the unit to function properly in a given limited distance modem environment:

64,000bps	17,000 feet	26 gauge wire
56,000bps	18,000 feet	26 gauge wire
38,400bps	20,000 feet	26 gauge wire
19,200bps	23,000 feet	26 gauge wire

9,600bps	20,000 feet	26 gauge wire
4,800bps	28,000 feet	26 gauge wire
2,400bps	31,000 feet	26 gauge wire

NOTE:

With 19 gauge wire, the above distances are approximately three times longer.

Clock settings for LDM operation are unique. For normal DDS operation, the units are set to “Slave Clock.” Timing is thus derived from the DDS network. For LDM operation, clock timing must be available from the units. This is accomplished by setting one of the two units to “Master Clock” and the other unit to “Slave Clock.”

Appendix A – Cable Diagrams

The DTE interface cable may be purchased from Raymar-Telenetics configured for RS-232 signaling. The following cables are required to make the connection between the primary channel of the unit and the data terminal equipment. These cables are wired as indicated in the two diagrams that follow.

Description	Pin	Source
Signal Clock	V-115	6440
Data Carrier Detect	F-109	6440
Receive Data	R-104	6440
Request To Send	C-105	6440
Transmit Data	P-103	6440
Signal Ground	B-102	6440
Inverted Clock	X-115	6440
Tx Clock	Y-114	6440
Inverse Receive Data	T-104	6440
Clear To Send	D-106	6440
Inverse Transmit Data	S-103	6440
Data Set Ready	E-107	6440
Tx Clock Inverted	AA-114	6440

Description	Pin	Source
Transmit Data	2	DTE
Receive Data	3	6440
Request To Send	4	DTE
Clear To Send	5	6440
Data Set Ready	6	6440
Signal Ground	7	6440/ DTE
Data Carrier Detect	8	6440
Tx Clock (Sync Only)	15	6440
Rx Clock (Sync Only)	17	6440
Data Terminal Ready	20	DTE

Raymar Information Technology, Inc. Limited Warranty

One Year Limited Hardware Warranty

Raymar Information Technology, Inc., dba Raymar-Telenetics, warrants their products against defects in hardware, material and workmanship under normal use for one (1) year from the date of purchase. Raymar will, at no charge, either repair the product (with new or reconditioned parts), or replace it (with a new or reconditioned product). Repaired replacement products are warranted for either 90 days or the remainder of the original warranty period, whichever is longer. This warranty extends to the original end-user only.

What This Warranty Does Not Cover

This warranty does not cover: (a) software; (b) installation or service of the product; (c) conditions resulting from consumer damage such as improper maintenance or misuse, abuse, accident or alteration; (d) all plastic surfaces (including display screens) and all other exposed parts that are scratched or damaged due to normal use; (e) operation of our products with equipment not supplied by Raymar (f) products which have had the serial number removed or made illegible; or (g) products rented to others. This warranty applies only to hardware products manufactured by or for Raymar Information Technology, Inc. and identified by the Raymar-Telenetics trademark, trade name or product identification logo affixed to them. Refer to the Service and Support section of the User's Guide for service after the warranty expires. No warranty is made as to coverage availability or grade of service provided by the carrier.

General Provisions

This warranty sets forth Raymar's entire hardware responsibilities regarding this product. Repair, replacement or refund of the purchase price is at Raymar's discretion. THIS WARRANTY IS GIVEN IN LIEU OF ALL OTHER EXPRESS WARRANTIES, IMPLIED WARRANTIES, INCLUDING WITHOUT LIMITATION IMPLIED WARRANTIES OF MERCHANTABILITY AND FITNESS FOR A PARTICULAR PURPOSE, AND ARE LIMITED TO THE DURATION OF THIS LIMITED WARRANTY. IN NO EVENT SHALL RAYMAR BE LIABLE FOR DAMAGES IN EXCESS OF THE PURCHASE PRICE OF THE PRODUCT, FOR ANY LOSS OF USE, LOSS OF TIME, INCONVENIENCE, COMMERCIAL LOSS, LOST PROFITS OR SAVINGS, OR OTHER INCIDENTAL, SPECIAL OR CONSEQUENTIAL DAMAGES ARISING OUT OF THE USE OR INABILITY TO USE THIS RAYMAR PRODUCT, TO THE FULL EXTENT SUCH MAY BE DISCLAIMED BY LAW. WITHOUT LIMITING THE FOREGOING, RAYMAR SHALL HAVE NO LIABILITY FOR ANY DATA STORED IN OR USED WITH THE PRODUCT, INCLUDING THE RECOVERY COSTS OF SUCH DATA OR PROGRAMS.

State Law Rights

SOME STATES DO NOT ALLOW THE EXCLUSION OR LIMITATION OF INCIDENTAL OR CONSEQUENTIAL DAMAGES OR LIMITATIONS ON HOW LONG AN IMPLIED WARRANTY LASTS. THE ABOVE LIMITATIONS OR EXCLUSIONS MAY NOT APPLY TO YOU. This warranty gives you specific legal rights, and you may also have other rights which vary from State to State.

Provincial Law Rights

SOME PROVINCIAL LAWS DO NOT ALLOW THE EXCLUSION OR LIMITATION OF IMPLIED WARRANTIES, THE EXCLUSION OR LIMITATION OF WARRANTY COVERAGE IN CERTAIN SITUATIONS. SOME OF THE ABOVE LIMITATIONS OR EXCLUSIONS CONTAINED IN THIS LIMITED WARRANTY MAY NOT APPLY TO YOU. This warranty gives you specific rights, and you may have other rights which vary from province to province.

How To Use Raymar's Limited Warranty Service

To take advantage of this warranty, you must do the following:

- If you are having trouble with your product, contact Raymar service using the appropriate number from the Service and Support section of the User's Guide. If it is determined that your product requires service, you will be issued a Return Materials Authorization (RMA) form.
- Pack the defective product securely for shipping. Include only the units pre-approved by service on your RMA form.
- This warranty is void if the product is damaged in transit, you must insure your shipment.
- Ship the defective product, proof of date of purchase, and the RMA form to the address specified.
- Display your RMA number prominently on the outside of the shipping box. Customer is responsible for freight in, door to door. Raymar is responsible for return shipping costs.
- To ensure prompt service, please write on the RMA form a brief description of the problem you are experiencing with the product.

Raymar Information Technology, Inc.
7325 Roseville Road
Sacramento, CA 95842
Service Hotline (800) 747-1522

<http://support.telenetics.com> or e-mail to techsupport@raymarinc.com

Raymar Information Technology, Inc. Return Merchandise Authorization (RMA) Procedure

Before returning any Raymar-Telenetics product, an RMA number must be obtained.

The most convenient way to obtain an RMA number for a product purchased from Raymar-Telenetics is to call **1-800-747-1522 (+1-916-783-1951)**. When doing so, please have the following information ready:

- Company name
- Full billing address, as well as the address for the location where the product should be returned once repaired or replaced
- Telephone & Fax numbers
- Email address
- Product model number and serial number

For each item being returned, please include the product model number, the serial number, a description of the problem being encountered, and the cause of the problem (if known).

Please note that prior to authorizing a return, a product support specialist may call to verify that the product is properly installed or may ask you to perform tests to insure that the product has actually failed.

The product must be properly packed and returned to:

**Raymar-Telenetics
7325 Roseville Road
Sacramento, CA 95842**

The RMA number must be legibly displayed on the shipping carton. Raymar-Telenetics will not be responsible for any product returned without an RMA number.

If the product is out of warranty, estimates for repair rates and any applicable shipping costs will be communicated by a customer service representative. Currently, Raymar-Telenetics accepts purchase orders or credit cards as payment methods.

Repairs currently require 5 – 10 business days and are returned via UPS Ground.